

Omicron Rev S4

40÷850 kW



General

High efficiency modular multi-functional units for large 4-pipe systems.

Configurations

HE: high efficiency version

SLN: super low noise version

/LN: silenced unit

Strengths

- ▶ High efficiency in all operating modes
- ▶ Independent defrosting cycles for each circuit with evolved operating logic
- ▶ Eurovent certification
- ▶ Wide range
- ▶ BlueThink advanced control with integrated web server. Multilogic function and Blueeye® supervision system. (options)
- ▶ Flowzer: inverter driven pumps for each hydraulic module (options)



Omicron Rev S4

Application and operating principle	5
Product description	6
Versions	8
Options	9
Description of accessories	10
Refrigerant circuit accessories	10
Fan accessories	11
Hydraulic circuit accessories	12
Flowzer options	13
Electrical accessories	27
Network accessories	30
Other accessories	33
Technical specifications	35
Ecodesign	45
Electrical specifications	55
Hydraulic modules	57
User-side exchanger flow rate fields	58
User-side exchanger flow rate fields	59
Operating limits	60
Noise levels	61
Installation advice	64
Water characteristics	64
Glycol mixtures	64
Minimum water content in the system	65
Installation site	66
Installations that require the use of treated coils	67
Aeraulic head losses and options available for the ventilating section	68
Dimensional diagrams	69
Dimensional diagrams	70
Dimensional diagrams	71
Dimensional diagrams	72
Dimensional diagrams	73
Dimensional diagrams	74
Dimensional diagrams	75
Dimensional diagrams	76



Omicron Rev S4

APPLICATION AND OPERATING PRINCIPLE

Multi-purpose units are machines designed for use in all applications where there may be a simultaneous and independent demand for hot and cold water production.

In particular, this occurs for all systems that use 4-pipe terminals, such as for example dual aspect buildings, buildings with large glazed surfaces or high-insulation buildings with non-homogeneous crowding levels.

The 4-pipe multi-purpose unit is able to meet simultaneous and independent heat loads of opposite sign, with the advantage of working in heat recovery operation: whenever there is a simultaneous demand for cooling and heating, the multi-purpose unit will work in recovery mode, and move the thermal energy from rooms that need to be cooled to those that need to be heated.

If the two heat loads are not balanced, then the controller works in mixed mode to recover as much thermal energy as possible and use the air exchanger as heat source with which to exchange the missing amount of capacity for meeting both demands of the system.

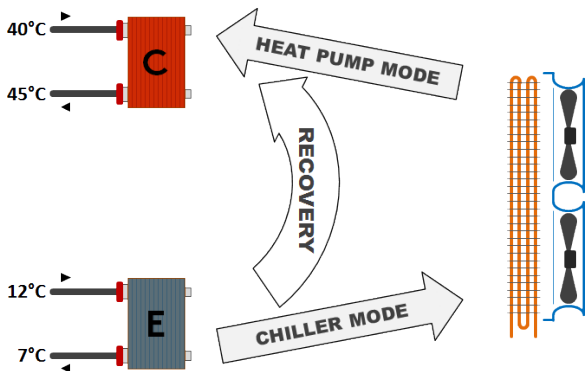

The 4-pipe multi-purpose unit can therefore work indirectly all year round to meet all the thermal and cooling energy demands of the system and is therefore an alternative to conventional systems based on the chiller/boiler combination with the additional non-negligible advantage of waste heat recovery.

Depending on the various scenarios that can occur over the span of a day, the multi-purpose unit can work with different modes and change from one to another fully automatically.

Cooling mode

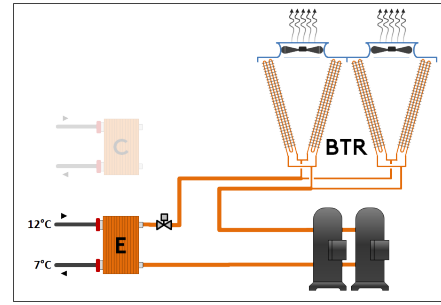

The unit works in this mode when the system requires only cold water production. It uses the finned coil "BTR" as source-side heat exchanger and produces chilled water at exchanger "E", connected to the circuit dedicated to water distribution for only air conditioning in the building.

Heating mode

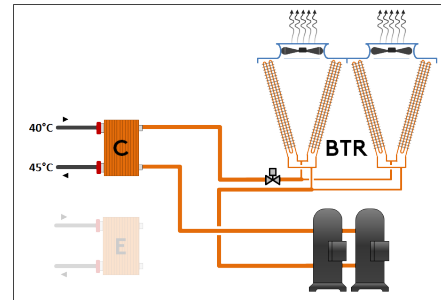

The unit works in this mode when the system requires only heating. It uses the finned coil "BTR" as source-side heat exchanger and produces hot water at exchanger "C", connected to the circuit dedicated to water distribution for only heating in the building.

Cooling + heating mode

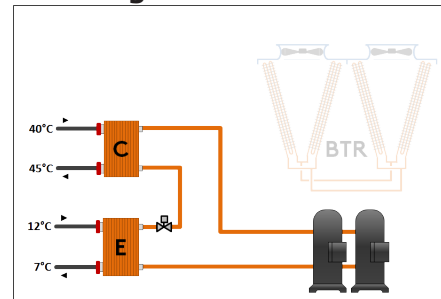

When there is a simultaneous demand for hot water and cold water in the system, the multi-purpose unit behaves like a water/water heat pump, and manages condensation on exchanger "C" and evaporation on exchanger "E" and therefore works simultaneously on the two hydronic circuits of the system.

The change from one configuration to another takes place fully automatically while trying to optimize the energy spent based on the demand from users.

Since all the units are also multi-circuit, the recovery mode can be used on one circuit while the other works in cooling or heating mode, and this is essential to meet unbalanced hot/cold load demands and in any case obtain the maximum level of energy recovery.

High efficiency modular multi-functional units for large 4-pipe systems.

PRODUCT DESCRIPTION

BODY

The body is modular with a load-bearing frame, made of galvanized sheet-iron coated with polyester powder RAL 5017/7035 which makes it highly resistant to weather conditions. All screws and bolts are stainless steel.

COMPRESSORS

The compressors are hermetic orbiting spiral scroll compressors connected in tandem for sizes 10.4-82.8, single for sizes 3.2-16.2

Fitted with oil level sight glass, oil equalization line and electronic protection.

SOURCE-SIDE HEAT EXCHANGER

The exchangers are made with finned pack coils with copper tubes and aluminium fins.

The coil/fan sections are made so as to be completely separate between the refrigerant circuits. This allows management of independent, never simultaneous, defrost cycles.

The coils have an increased fin pitch to reduce frost formation and to facilitate the outflow of condensed water during defrosting.

The V-shaped arrangement of the coils enables them to be protected from hail and makes the unit compact. It also guarantees an increase in the air intake surface, and leaves ample space for distribution of the components of the refrigerant circuit and the hydraulic circuit.

To protect the exchangers from corrosion and ensure optimal operation of the unit, we advise following the recommendations given in the user, installation and maintenance manual for cleaning the coils. For installations within a kilometre of the coast, use of the accessory is strongly recommended Coil treated with anti-corrosion paints.

FANS

The fans are axial fans, directly coupled to a three-phase 6-pole electric motor, with integrated thermal overload protection (Klixon®) and IP 54 protection rating.

The fan includes the shroud, designed to optimize its efficiency and reduce noise emission to a minimum, and the safety guard.

COLD USER-SIDE HEAT EXCHANGER

Models 3.2÷ 43.4

The exchanger is a dual circuit, braze-welded stainless steel plate heat exchanger, insulated with a shroud of closed-cell insulating material.

On the hydraulic connections of the heat exchanger, there are pipe taps for the differential pressure switch, and wells for the temperature probes.

The exchanger is also equipped with thermostat-controlled anti-freeze heater to protect it from ice formation when the unit is not running.

Models 51.6 ÷ 82.8

The exchanger is a dry-expansion shell-and-tube exchanger.

It is sized to maximize the efficiency of the unit, by keeping the overall dimensions and the refrigerant charge down to a minimum.

The exchanger consists of a steel shell insulated with a shell made of closed-cell foam material, while the tube bundle is made with copper tubes.

Depending on the model, the exchanger is with three or four refrigerant circuits.

On the hydraulic connections of the exchanger, there are also pipe taps for the differential pressure switch and wells for the temperature probes.

The exchanger is also equipped with thermostat-controlled anti-freeze heater to protect it from ice formation when the unit is not running.

HOT USER-SIDE HEAT EXCHANGER

Models 3.2÷ 43.4

The exchanger is a dual circuit, braze-welded stainless steel plate heat exchanger, insulated with a shroud of closed-cell insulating material.

On the hydraulic connections of the heat exchanger, there are pipe taps for the differential pressure switch, and wells for the temperature probes.

The exchanger is also equipped with thermostat-controlled anti-freeze heater to protect it from ice formation when the unit is not running.

Models 51.6 ÷ 82.8

The exchanger is a flooded shell-and-tube condenser.

It is sized to maximize the efficiency of the unit, by keeping the overall dimensions and the refrigerant charge down to a minimum.

The exchanger consists of a steel shell insulated with a shell made of closed-cell foam material, while the tube bundle is made with copper tubes.

Depending on the model, the exchanger is with three or four refrigerant circuits.

On the hydraulic connections of the exchanger, there are also pipe taps for the differential pressure switch and wells for the temperature probes.

The exchanger is also equipped with thermostat-controlled anti-freeze heater to protect it from ice formation when the unit is not running.

REFRIGERANT CIRCUIT

The unit uses refrigerant gas R410A.

Each refrigerant circuit of the unit comprises:

- shut-off valve in the liquid line
- 5/16" charging valves
- liquid sight glass
- replaceable solid cartridge dehydrator filter
- two electronic expansion valves per circuit
- mechanical thermostatic valve dedicated to defrosting
- 4-way reversing valve
- suction separator
- fluid accumulator
- pressure transducers for reading high and low pressure values
- high pressure switches
- safety valves

The pipes of the circuit and the exchanger are insulated with extruded closed-cell expanded elastomer that is resistant to UV rays.

ELECTRICAL CONTROL PANEL

The electrical control panel is made in a painted galvanized sheet-iron box with forced ventilation and IP54 protection rating.

The electrical control panel of the basic unit comprises:

- main disconnect switch
- automatic circuit breakers for compressors with fixed calibration
- fuses for protecting the fans and auxiliary circuits
- fan contactors
- phase-cutting fan speed adjuster
- thermal magnetic circuit breakers for pumps (if present)
- phase monitor
- potential-free general alarm contacts
- single potential free operating contacts for compressors, fans and pumps (when present)
- digital input for general ON/OFF
- digital input for cold circuit ON/OFF
- digital input for hot circuit ON/OFF
- external air temperature probe
- microprocessor controller with display accessible from the outside

All the electrical cables inside the panel are numbered and the terminal board dedicated to the customer's connections is coloured orange so that it can be quickly identified in the panel.

Standard power supply of the unit is 400V/3~/50Hz

CONTROL BLUETHINK

Main controller functions

The microprocessor control allows the following functions:

- water temperature control, with control of water at the inlet on the cold exchanger and on the hot exchanger
- freeze protection
- compressor timings
- automatic rotation of compressor starting sequence
- recording of the log of all machine inputs, outputs and states
- automatic rotation of compressor starting sequence
- recording of the alarm log
- sliding defrost management
- sliding defrost management
- management of independent, never simultaneous, defrosts on the various refrigerant circuits
- digital input for general ON/OFF
- digital input for cold circuit ON/OFF
- digital input for hot circuit ON/OFF
- RS485 serial port with Modbus protocol
- Ethernet serial port with Modbus protocol and integrated web server preloaded web page

For further details on available functions and on displayed information, you can refer to the specific documentation of the control.

By default, the serial connections present as standard are enabled only for reading from BMS. Enabling of writing from BMS is to be requested when ordering.

Main functions of the webserver

As standard, the Bluethink controller integrates a web-server with a preloaded web page that is accessed via password.

The web page allows the following functions to be carried out (some of these are available only for users with advanced level rights):

- display of the main information on the unit, such as serial n°, size, type of refrigerant
- display of the general status of the machine: water inlet and outlet temperatures, external air temperature, operating mode, evaporating and condensing pressures, suction and discharge temperatures
- display of the status of compressors, fans, pumps, electronic expansion valves
- display in real time of the graphs of the main quantities
- display of the graphs of logged quantities
- display of alarm log
- display of the status of all the I/Os of the controller
- management of users on several levels
- remote ON/OFF
- remote set point change
- remote time band change
- remote summer winter mode selection

Human-Machine Interface

The control has a graphic display that allows the following information to be displayed:

- water inlet and outlet temperature
- set temperature and differential set points
- description of alarms
- hour meter of operation and number of start-ups of the unit, the compressors and the pumps (if present)
- high and low pressure values, and relevant condensing and evaporating temperatures
- external air temperature
- superheating at compressor suction.

Management of defrost cycles

For defrost management, the control of the unit uses a sliding intervention threshold, depending on the pressures inside the unit and the external air temperature. By putting together all this information, the control can identify the presence of ice on the coil and activates the defrosting sequence only when necessary, so as to maximize the energy efficiency of the unit.

Sliding management of the defrost threshold ensures that, as the absolute humidity of outdoor air decreases, the frequency of the defrost cycles gradually decreases because they are carried out only when the ice formed on the coil actually penalizes performance.

CONTROLS AND SAFETY DEVICES

All the units are fitted with the following control and safety components:

- high pressure switch with manual reset
- high pressure safety device with automatic reset, for a limited number of occurrences, managed by the controller
- low pressure safety device with automatic reset and limited tripping managed by the controller
- high pressure safety valves
- antifreeze probe at the outlet of the user-side heat exchangers
- differential pressure switch already fitted on the user-side heat exchangers
- overtemperature protection for compressors and fans

TESTING

All the units are factory-tested and supplied complete with oil and refrigerant.

PACKAGING

There are yellow lifting brackets at the base of the unit to allow lifting with lifting beam.

The unit is wrapped in a protective transparent polyethylene stretch film.

VERSIONS

Omicron Rev S4 HE

These units involve the use of exchangers with high exchange surface area in order to make high efficiency units.

Omicron Rev S4 SLN

These units involve the use of a soundproofed compressor compartment and fans with speed adjuster calibrated with a reduced air flow rate. The speed reduction of the fans is such that, under nominal operating conditions in chiller mode, the air flow rate and noise level are lower than those of the high efficiency version of the unit.

In any case, the use of the speed adjuster to reduce the air flow rate allows rotation of the fans at maximum speed when external air temperature conditions are particularly critical and therefore guarantees the same operating limits as the high efficiency versions.

In heat pump mode, the fans always operate at 100% speed and therefore guarantee the same performance levels as the high efficiency version.

OPTIONS

/LN: silenced unit

In the unit with /LN option, all the compressors are enclosed in a compartment that is fully soundproofed with sound absorbing material and soundproofing material.

HYDRAULIC MODULES

All units can be fitted with hydraulic module in various configurations:

- /1P/1R: hydraulic module with one pump on the cold circuit and one pump on the hot circuit
- /2P/2R: hydraulic module with two pumps on the cold circuit and two pumps on the hot circuit

The hydraulic modules with one pump per circuit (/1P/1R) have:

- one pump on the cooling circuit and one pump on the heating circuit
- a gate valve on the delivery side of each pump
- a safety valve on each hydraulic circuit set to 6bar

The hydraulic modules with two pumps per circuit (/2P/2R) have:

- two pumps on the cooling circuit and two pumps on the heating circuit
- a check valve on the delivery side of each pump
- a safety valve on each hydraulic circuit set to 6bar

In the version with 2 pumps, these are always with one on standby while the other is working. Switching over between the pumps is automatic and is done by time (to balance the hours of operation of each one) or in the event of failure.

DESCRIPTION OF ACCESSORIES

Refrigerant circuit accessories

Some accessories may be incompatible with each other even if not expressly indicated.

BC Capacitive backup battery for electronic expansion valve

When the compressors stop, the controller always closes the electronic expansion valve to prevent dangerous refrigerant migration. The presence of the backup battery ensures that the electronic valve is kept in closed position even when there is no power supply

This option uses a condenser as energy storage, and not an ordinary coil. In this way, it is not affected by the memory effect of normal coils and the need for maintenance is avoided.

BK Brine Kit

This accessory is compulsory if a water temperature set point lower than +3°C is used (if the unit is provided with double set point or variable set point, the lower set point is considered).

The accessory consists of increased insulation and suitable sizing and calibration of some components.

The inlet and outlet temperatures of the user-side exchanger must be given on ordering to allow correct setting of the alarm parameters and verification of the sizing of the expansion valve.

The cooling set point can then be changed by the customer in an interval that, compared to the set point given on ordering, ranges from -1K up to the maximum temperature allowed by the above-stated operating limits.

The unit will be optimized to work at the set point temperature given on ordering. For different set points, the cooling capacity provided and the level of efficiency of the machine could decrease and move away from these conditions.

DVS Double safety valve

With this accessory, instead of each individual safety valve per circuit, there is a "candelabrum" with two safety valves and a diverter valve for choosing the valve in operation. This allows the safety valves to be replaced without having to drain the machine and without having to stop it.

MAFR Pressure gauges

The operating pressures of each circuit of the unit can be displayed on the control by accessing the relevant screens. Also, the machine can be fitted with pressure gauges (two for each circuit) installed in a clearly visible position. These allow reading in real time of the working pressures of the refrigerant gas on the low pressure side and on the high pressure side of each refrigerant circuit.

RG Fan speed adjuster (S)

The control manages the speed of the fans through a phase cutting speed adjuster, in order to optimize the operating conditions and efficiency of the unit.

This control also has the effect of reducing the noise level of the unit: in fact, the typical conditions under which the control will be modulating the speed of the fans are those of the night, spring and autumn.

For units equipped with EC fans, the same function is carried out using the electronically commutated motor of the fans and is supplied as standard.

RPP Refrigerant leak detector with automatic pump down

With this accessory, a refrigerant leak detector is placed inside each compressor compartment. Detection of a refrigerant leak is managed by the control through a specific alarm and display of a specific icon on the display of the control. For all the circuits of the unit, the alarm also starts the machine stopping procedure with pump down, confining all the refrigerant in the coils.

The accessory includes the capacitive backup battery.

The accessory can be applied only to units in LN or SLN set-up.

RPR Refrigerant leak detector

With this accessory, a refrigerant leak detector is placed inside each compressor compartment. Detection of a refrigerant leak is managed by the controller through a specific alarm and display of a specific icon on the display of the controller. This alarm stops the unit.

RUB Compressor suction and delivery valves

The valves situated on the delivery side and on the suction side of the compressors allow the compressor to be isolated from the rest of the refrigerant circuit, so making the maintenance operations quicker and less invasive

Fan accessories

VEC EC fans

With this accessory, EC fans, with electronically commutated brushless motor, are used for the ventilating section. These guarantee very high efficiency levels for all working conditions and allow a 15% saving on the power absorbed by each fan working at full capacity.

Also, through a 0-10V analogue signal sent to each fan, the microprocessor carries out condensation/evaporation control by continuous adjustment of the air flow rate as the external air temperature changes, with a further reduction in electrical absorption and noise emission.

For further details, see the dedicated chapter: "Aeraulic head losses and options available for the fan section".

VEM Oversize EC fans

The increased EC fans allow to obtain the same benefits as EC fans and in addition allow to have a residual useful head of about 100Pa.

For further details, see the dedicated chapter: "Aeraulic head losses and options available for the fan section".

RECP Pressure recuperator

Not available for 2 compressors units (XX.2)

Normally, the air ejected by the fan has a high speed and this manifests itself as kinetic energy that is dissipated into the environment.

The pressure recuperator is a passive element situated on the ejection duct of each individual fan designed to allow better conversion of kinetic energy into static pressure, which manifests itself as a higher pressure generated by the fan.

This higher pressure can have at least two possible applications:

- For the same fan speed, the pressure recuperator allows an increase of about 50Pa in the available pressure of the ventilating section to be obtained. This can be useful for overcoming the head losses that may be present in specific installations. The increase in available pressure is to be considered in addition to the increase that can already be obtained with the application of oversize EC fans
- for the same pressure differential on the air, the pressure recuperator allows the same air flow rate to be obtained with a lower number of revolutions of the fan. This automatically produces a reduction of up to 3 dB(A) in the noise emission of the unit and a reduction in the absorption of the fan, with an immediate increase in the overall efficiency of the unit.

The reduction in total sound power varies depending on the model and version of the unit as it is related to the incidence of noise generated only by the fan section on the total noise emitted by the unit.

For SLN units, which already work with a reduced air flow rate, application of the pressure recuperator has a limited or negligible noise reduction effect.

To allow optimization of the performance of the accessory, combination with the speed adjuster or EC fans is necessary. In this last case, the higher efficiency of the EC fans (especially when operating at low speed) is added to the performance improvement generated by the pressure recuperator.

The accessory is supplied separately from the unit on one or more pallets and it must compulsorily be installed (by the customer) before the first start-up of the machine.

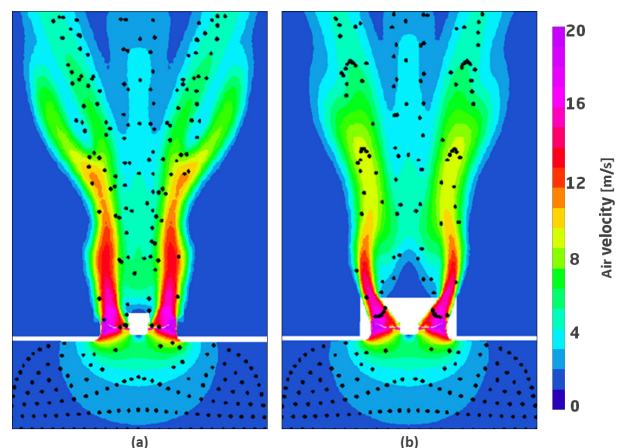
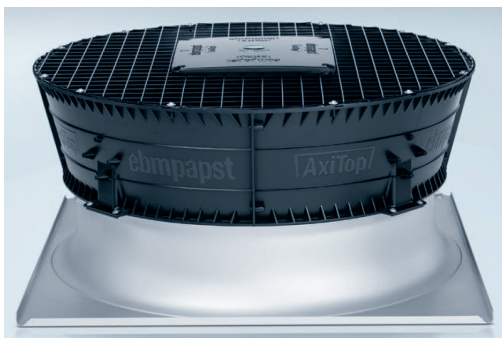

(a) fan only;

(b) fan with pressure recuperator

Hydraulic circuit accessories

IVPO Soundproofed pump compartment

With this accessory, the motor and the impeller of the pumps are enclosed in a compartment that is fully soundproofed with sound absorbing material and soundproofing material.

RA Antifreeze heater

These are electric heaters inserted on the user-side heat exchanger, on the pumps and in the tank (depending on the configuration of the machine) to prevent damage to the hydraulic components due to ice formation during periods when the machine is stopped.

The antifreeze heater is present as standard on both user-side heat exchangers.

FLUS Flow switches on both hydraulic circuits (in place of water differential pressure switches)

As an alternative to the differential pressure switch (standard flow sensor), it is possible to request the paddle flow switch as accessory. This detects when there is no water flow to the user-side exchanger and sends a signal to the control of the unit that will stop the compressors to prevent damage to the exchangers.

Application of this accessory is compulsory for units that use non-glycol water and work with a yearly cycle where external air temperatures are zero or below.

The flow switch is supplied loose (installation by the customer) and replaces the water differential pressure switch (standard).

PFPP User-side pump with Pulse function cold circuit

PFPC User-side pump with Pulse function hot circuit

As standard, the unit is set to keep the system-side circulation pump on all the time, even when the set point temperature is reached.

But when the unit is provided with this accessory, on reaching the set point, the controller will switch off the pump and start it again at regular intervals for a sufficient time to measure the water temperature. If the controller verifies that the water temperature is still in set point condition, it will switch off the pump again. Otherwise the controller will start the compressors again to meet the requirements of the system.

This accessory therefore allows electrical absorption due to pumping to be drastically reduced, especially in spring and autumn when the load is extremely low.

V3MC 3-way modulating valve on hot circuit

The accessory involves the supply of a 3-way modulating valve to be inserted on the hot circuit in order to check that the temperature of the water entering the exchanger is always higher than the minimum allowed.

VSIW Safety valve on both circuits (S)

With this accessory, a safety valve is inserted in the hydraulic circuit of the unit: when the calibration pressure is reached, the valve opens and, by discharging (to be routed by the customer), prevents the system pressure from reaching limits that are dangerous for the components present in the system. The valves have positive action, that is, performance is guaranteed even if the diaphragm deteriorates or breaks.

The safety valve is inserted as standard on both hydraulic circuits.

Flowzer options

Our range of Flowzer options offers flexible and scalable solutions to set the speed of pumps in the system with a view to optimising and reducing energy consumption. Different types of control modes are offered based on the system and application type:

- FLOWZER VP - Inverter for manual pump adjustment
- FLOWZER VD - control of available pump discharge head for variable flow systems without monitoring the flow rate limits;
- FLOWZER VDE - flow rate control to keep the flow rate constant as the external working conditions of the system change;
- FLOWZER VDT - flow rate control with constant TD (difference between input and output temperature in the heat exchanger on the user side) in variable flow pumps, without monitoring the flow rate limits;
- FLOWZER VFPP - automatic management of variable flow rate in systems with one single primary circuit and a bypass valve;
- FLOWZER VPS - automatic management of variable flow rate, including balancing of flow rates between primary and secondary circuits;
- flowzer vps with TD-based control - automatic management of variable flow rate, including control with constant TD (difference between input and output temperature in the heat exchanger on the user side) in systems featuring both the primary and secondary circuits.

The tables below summarise the main system diagrams and show the application type and advantages/disadvantages offered by each solution. Each individual option is illustrated and explained individually in the next pages.

The hydraulic diagrams in this document are for exemplification purposes only and their main function is to help the reader understand the type of machines and devices the controller can manage. For a more technical evaluation of the system, please refer to the dedicated manual.

Constant flow system			
	Application	Advantages	Disadvantages
Flowzer VP	Ideal for constant flow systems The option is given to set two different speeds: one for heating and one for cooling mode or one for chiller and one for FC mode. This solution replaces the 2-way regulating valve.	- Increased efficiency: increased "REAL" EER of the unit installed, considering the power consumption of the pumps in real installation conditions and in real operating conditions. - Reduced installation times and costs: quick setup of water flow using the display.	This solution doesn't allow to save energy in the pump under part load conditions, due to the possibility to only set two frequency values in the inverter.
Flowzer VDE	Ideal for constant flow systems to keep the water flow to the heat exchanger constant under all conditions	- Plug&Play: provides for easy and flexible implementation as it is not supplied with options to be fitted therefore allows for quick commissioning.	This solution is less efficient as losses in the heat exchanger are kept constant under all conditions (including in cases when they may be reduced).

FLOWZER VP

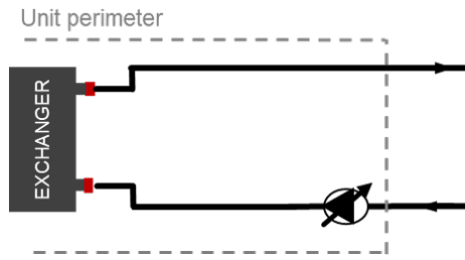

FLOWZER VDE

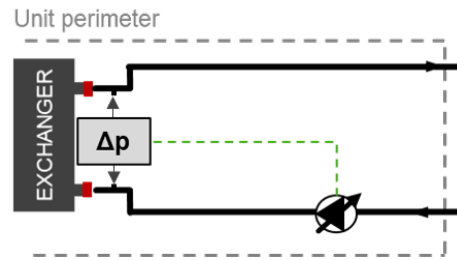

Variable flow system featuring primary and secondary circuits

	Application	Advantages	Disadvantages
Flowzer VPS	Ideal for all systems featuring a primary and a secondary circuit divided by a hydraulic bypass branch	<ul style="list-style-type: none"> - Energy saving: the energy consumption during pumping operations can be cut down to 55% if compared with a traditional system - Enhanced comfort: correct balancing between primary and secondary loop 	Only recommended in systems featuring a primary and a secondary circuit divided by a bypass pipe; not flexible for other applications
Flowzer VDT	Ideal for systems featuring similar users or users with similar operating conditions. It is recommended in structured systems in which the client has third-party systems to control the min. and max. flow rate.	<ul style="list-style-type: none"> - Plug&Play: provides for easy and flexible implementation as it is not supplied with options to be fitted and for quick commissioning. 	Risk of over- or underflow for some of the users in the secondary circuit if they have different operating conditions (same temperature difference). A control is required by third-party equipment to ensure compliance with the unit flow limits.
FLOWZER VPS with TD-based control	Ideal for systems featuring similar users or users with similar operating conditions. Ideal for systems featuring a primary and a secondary circuits physically divided from the heat exchanger or a tank with multiple connections.	<ul style="list-style-type: none"> - Plug&Play: provides for easy and flexible implementation as it is not supplied with options to be fitted and for quick commissioning. 	Risk of over- or underflow for some of the users in the secondary circuit if their temperature difference is not the same due to the existing operating conditions

FLOWZER VPS

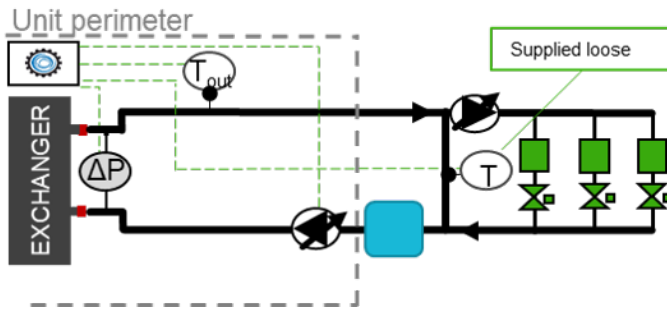

FLOWZER VDT

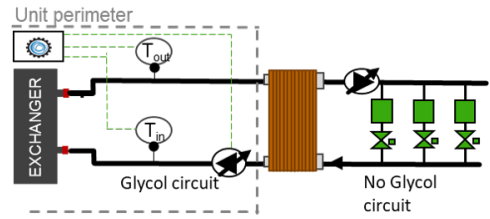
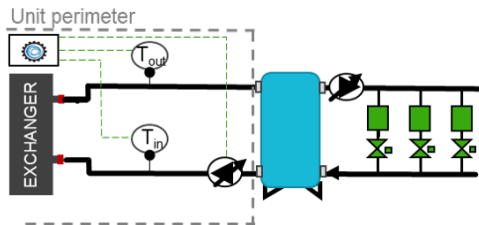

FLOWZER VPS with DT-based control

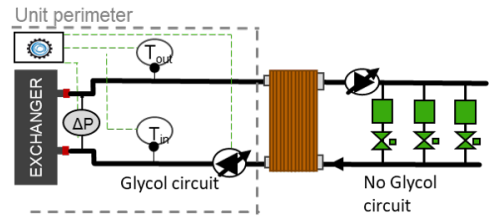
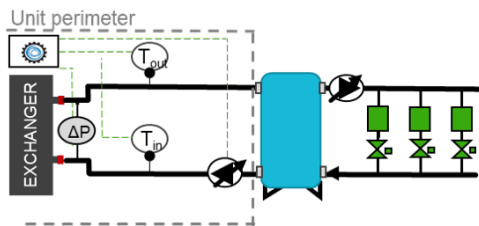

Variable flow system featuring primary circuit only

	Application	Advantages	Disadvantages
Flowzer VFPP	Ideal for new systems intended to reduce installation costs	- Energy saving: the energy consumption during pumping operations can be cut down to 50% if compared with a traditional system Lower CAPEX thanks to reduced installation costs and smaller number of components (one pump less)	Requires some testing to correctly set the pressure available in the system and to correctly position the two transducers, based on the system layout and devices.
Flowzer VD	Ideal for systems fitted with changing users according to the season. Ideal for industrial processes, such as injection moulding, in order for each terminal to operate with the correct discharge head. It is recommended in structured systems in which the client has third-party systems to control the min. and max. flow rate.	- Plug&Play: provides for easy and flexible implementation as it is not supplied with options to be fitted therefore allows for quick commissioning.	A control is required by third-party equipment to ensure compliance with the unit flow limits.

Flowzer VFPP

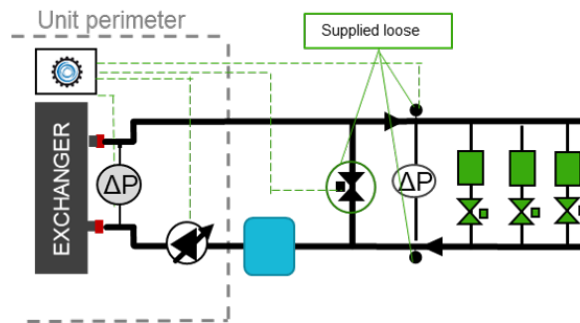

Flowzer VD

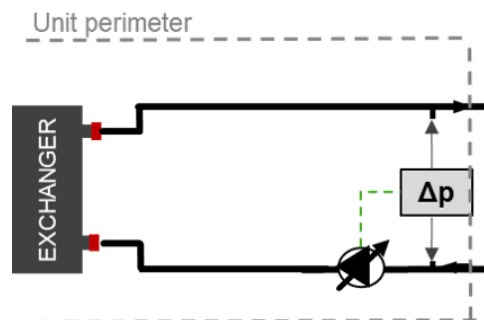

FVPF FLOWZER VP - Inverter for manual pump adjustment cold circuit
FVPC FLOWZER VP - Inverter for manual pump adjustment hot circuit

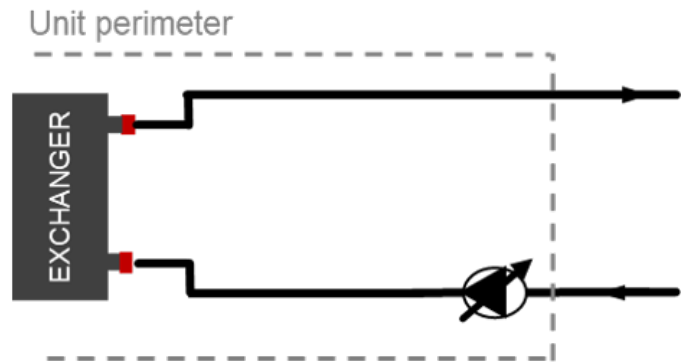

The accessory consists of inserting an inverter in the machine to manually adjust the speed of the pump (or pumps) in order to calibrate the pump flow rate on the head losses of the system.

This accessory is to be combined with one of the integrated hydraulic modules that can be selected for the unit. Units equipped with integrated hydraulic module allow a certain level of available discharge head (point A) to be obtained under nominal flow rate conditions Q_d .

But the actual head loss level of the system (e.g. characteristic curve R') normally causes the pump to find a different equilibrium point (point B), with a flow rate Q_r higher than Q_d .

In this condition, in addition to having a different flow from the nominal one (therefore also a different temperature jump), there is also a greater absorption of electric power from the pump itself.

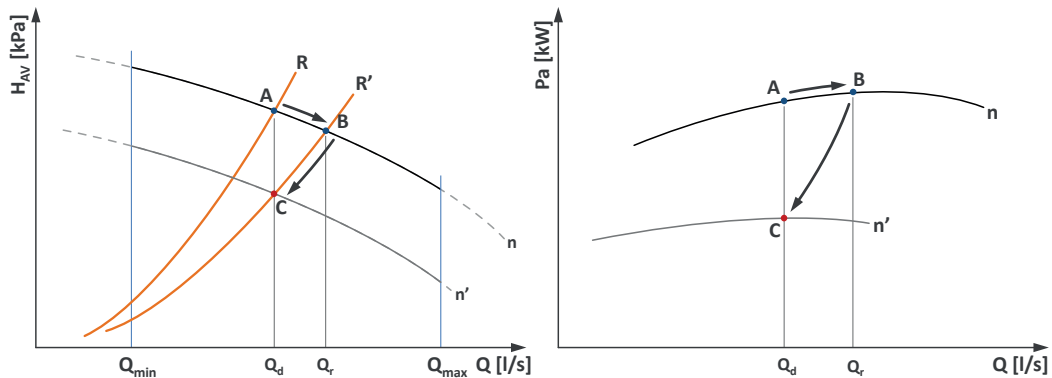

The use of the Flowzer allows the pump speed to be set manually (e.g. at speed n' instead of n) to obtain the design water flow rate and thermal gradient (point C). Once the adjustment procedure has been carried out, the pump will always work at a fixed flow rate.

The adoption of the VP Flowzer allows to considerably reduce the electrical power consumption of the pump with a consequent energy saving. By way of example, a reduction in the flow rate of 10% leads to a reduction in power consumption of around 27%.

For the freecooling units the Flowzer VP is able to manage two different speeds of the pump automatically compensating the pressure drops of the water coil.

- FVDF FLOWZER VD - control of available pump discharge head for variable flow systems without monitoring the flow rate limits; cold circuit**
- FVDC FLOWZER VD - control of available pump discharge head for variable flow systems without monitoring the flow rate limits; hot circuit**

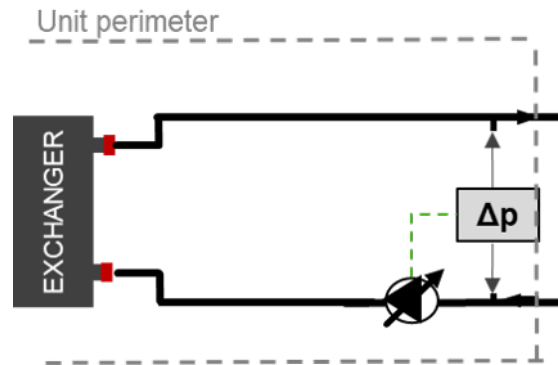

Flowzer VD requires two pressure transducers to be installed in the machine. Through these transducers, the inverter can gauge the actual pressure at the ends of the system and it can automatically adapt the pump speed to obtain a set available discharge head value. Flowzer VD must be combined with Flowzer VP. This accessory therefore allows a constant pressure system to be achieved.

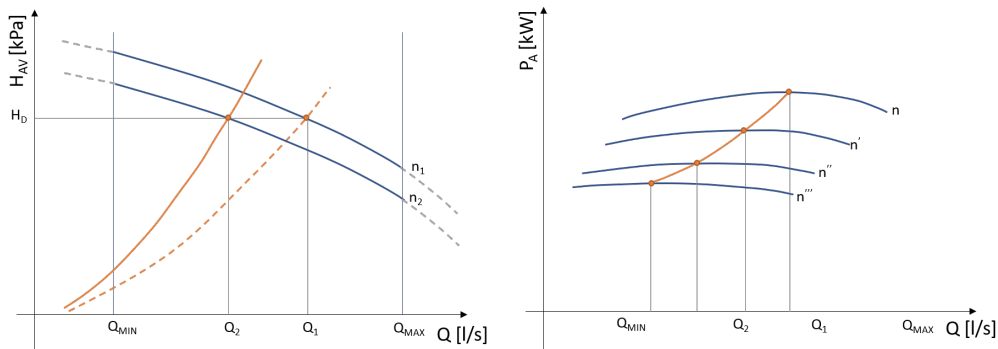

With the Flowzer VD, the customer can set, directly on the display, the available discharge head value (H_d) that the unit must maintain. As can be seen from the graph as the user request decreases, the resistant curve of the plant moves to the left, consequently the inverter reduces the speed of the pump in order to maintain the useful head necessary for the unit. With this system a significant reduction in electrical power is achieved. The customer will have to check that, in minimum flow rate conditions (that is, with the maximum number of user points closed), this is always higher than or equal to the minimum flow rate allowed by the unit.

This accessory is useful when the total head losses of the circuit are slightly variable or when they change depending on the seasons (for example, some user points are active only during summer operation and not during winter operation).

The use of this accessory also allows the pump speed to be adapted to possible fouling of the filter on the hydraulic circuit.

- FVDEF FLOWZER VDE - flow rate control to keep the flow rate constant as the external working conditions of the system change; cold circuit**
- FVDEC FLOWZER VDE - flow rate control to keep the flow rate constant as the external working conditions of the system change; hot circuit**

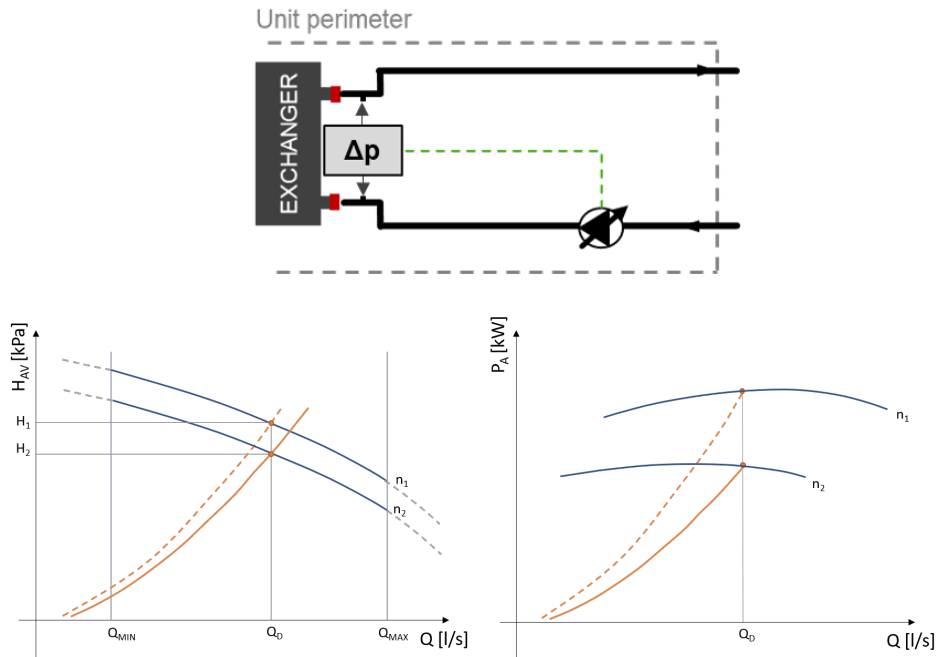

Flowzer VDE is used to automatically adjust the pump speed. As the graph shows, the inverter trips and increases the pump speed if a different condition occurs which would cause an undesired drop in the flow rate (e.g. operation of an external dry cooler). This is a more accurate solution than the VP option alone as it always provides for the water flow (Q_d) required by the design conditions.

Flowzer VDE requires a differential pressure transducer to be installed in the machine. Through this transducer, the inverter can gauge the actual pressure at the ends of the heat exchanger installed in the machine and it can automatically adapt the pump speed for a constant flow value under all conditions. Flowzer VDE must be combined with Flowzer VP.

VDTF FLOWZER VDTF - constant TD-based control in the heat exchanger, with variable flow pump without monitoring the flow rate limits cold circuit

VDTC FLOWZER VDTC - constant TD-based control in the heat exchanger, with variable flow pump without monitoring the flow rate limits hot circuit

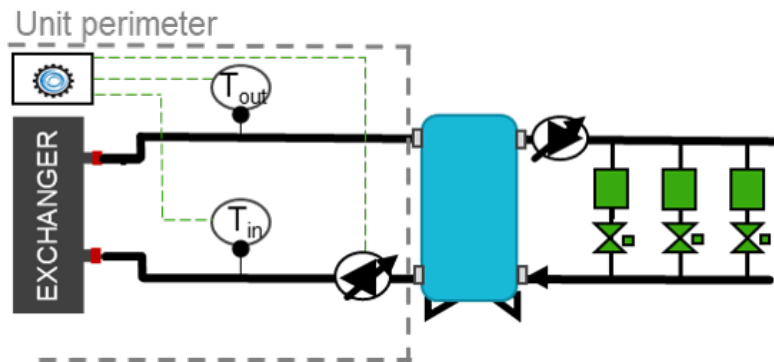

Flowzer VDT uses the temperature sensors installed at the inlet and outlet of the heat exchanger to automatically adjust the pump speed, thus keeping the T delta difference setpoint constant.

The option is not compatible with the Multilogic version. Please refer to the HYZER solutions for the compatibility between variable flow systems and multi-machine systems.

The unit must include the advanced Bluethink controller and just one heat exchanger on the user side.

With the Flowzer VDT, the customer can set, directly on the display, the available discharge head value that the unit must maintain. The customer will have to check that, in minimum flow rate conditions (that is, with the maximum number of user points closed), this is always higher than or equal to the minimum flow rate allowed by the unit.

This option is specifically designed for systems in which the system users have similar operating conditions (same temperature difference).

- FVFF FLOWZER VFPP - automatic management of variable flow rate in systems with one single primary circuit and a bypass valve; cold circuit**
- FVFC FLOWZER VFPP - automatic management of variable flow rate in systems with one single primary circuit and a bypass valve; hot circuit**

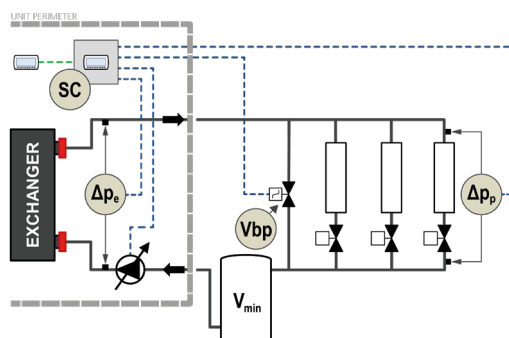

Bluethink solution for a variable flow rate system, consisting solely of a user-side primary circuit.

Flowzer VFPP includes:

- a pressure transducer installed at the ends of the user-side exchanger (Δp_e)
- a dedicated control system, installed at the factory in the electrical control panel of the unit (Sc)
- a modulating bypass valve with servo-motor supplied separately with it (Vbp), supplied loose (installation by the customer)
- two system pressure transducers (Δp_p) supplied separately (installation by the customer)

It is obligatory for the option to be combined with the Flowzer VP (inverter) and with one of the hydraulic modules that can be selected for the unit. The accessory is not compatible with Multilogic. Please contact our sales department for further details.

The unit must include the advanced Bluethink controller, just one heat exchanger on the user side and a minimum capacity step of 25% or less.

The option offers a complete default package to guarantee simple selection, purchasing and commissioning.

Flowzer VFPP has the advantage of:

- implementing an innovative design, which is alternative to the classic system based on fixed flow-rate primary circuit plus secondary circuit
- being ideal for new or entirely redesigned systems, especially for comfort applications
- having a variable flow system, with maximum energy saving
- simplifying the layout of the user circuit
- limiting the capex of the system
- performing a reliable check

The Flowzer VFPP system controller uses an advanced algorithm that enables prevention of unnecessary waste of energy and hunting by the inverter and the bypass valve.

The capex of the system is also reduced thanks to:

- single inverter + pumping module, integrated in the unit
- small internal footprint, due to the simplified layout

The operating principle can be summarized as follows:

- Flowzer VFPP carries out constant control of the discharge head
- the controller modulates the pump speed according to the signal detected by the system transducers Δp_p
- as the demand from the system goes down, the pump speed will be reduced.
- the pump speed can be reduced until it reaches the minimum allowed flow rate on the heat exchanger of the unit
- this flow rate is indirectly monitored through the losses detected by the differential pressure transducer Δp_e
- When the minimum allowed flow rate threshold is exceeded, the control system will open the bypass valve Vbp to recirculate the flow rate that is not required by the system, but is necessary to guarantee the minimum flow rate to the heat exchanger.

In the required minimum load condition (that is, with all system terminals switched off) the necessary minimum volume (V_{min}) must be ensured by the relevant tank to be installed between the unit and the separator or the bypass pipe.

The bypass valve V_{bp} is controlled through a 0-10 V signal and must therefore be installed within 30 m of the unit.

The pressure transducers of the system Δp_p provide a 4-20 mA signal and require two 1/4" female fittings. These transducers must be installed within 200 m of the unit, near the system terminal that is affected by the highest line head losses or in any case in a position where it is possible to measure an adequate pressure value.

Further details can be found in the relevant manual.

HSxF HYZER E VPS function cold circuit

HSxC HYZER E VPS function hot circuit

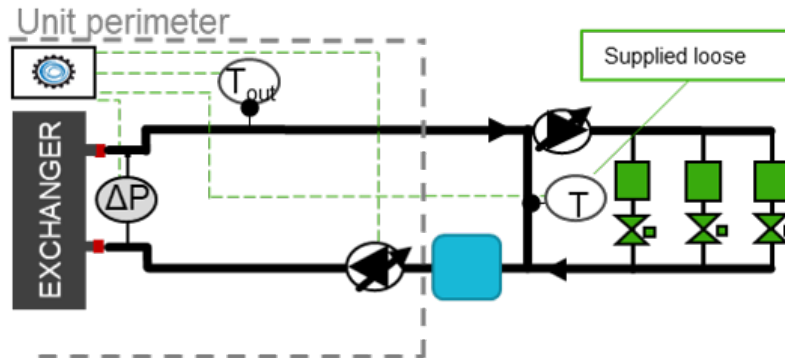

Bluethink solution for a variable flow rate system, consisting of a primary circuit plus secondary circuit.

It is obligatory for the option to be combined with the Flowzer VP (inverter) and with one of the hydraulic modules that can be selected for the unit. The accessory is not compatible with Multilogic. Please contact our sales department for further details.

The unit must include the advanced BlueThink controller and just one heat exchanger on the user side.

The option offers a complete default package to guarantee simple selection, purchasing and commissioning.

Flowzer VPS has the advantage of:

- being ideal for renovations of existing systems, especially for comfort applications
- achieving a complete variable flow system, with maximum energy saving
- implementing a flexible design, e.g. for scalable or multi-zone systems

The maximum energy saving is achieved thanks to the advanced algorithm, which prevents hunting by the inverter and balances the pump speed and the recirculation flow rate to a minimum.

With refurbishments, the system's capex is limited to the unit and its commissioning.

The dimensions of the inverter of the unit and of the pump module can be favoured by the low design discharge head of the primary circuit.

The operating principle can be summarized as follows:

- Flowzer VPS performs a smart check of the flow rate in the primary circuit and balances it with the flow rate in the secondary circuit.
- the system controller modulates the pump speed according to the condition detected by the system sensors T
- if the system terminals are switched off, the flow rate of the secondary circuit will decrease; therefore the direction of flow is detected indirectly as temperature difference by the system sensors through the separator or the bypass pipe
- The check thus contributes to reducing the speed of the primary pump until the min. flow threshold in the heat exchanger of the unit is exceeded.

• this flow rate is indirectly monitored through the losses detected by the differential pressure transducer Δp_e
In the required minimum load condition (that is, with all system terminals switched off) the necessary minimum volume (V_{min}) must be ensured by the relevant tank to be installed between the unit and the separator or the bypass pipe.

The temperature sensors of the system T provide a 4-20 mA signal and require 1/2" female fittings.

Further details can be found in the relevant manual.

FVPSF flowzer vps with TD-based control - automatic management of variable flow rate, including control with constant TD (difference between input and output temperature in the heat exchanger on the user side) in systems featuring both the primary and secondary circuits. cold circuit

FVPSC flowzer vps with TD-based control - automatic management of variable flow rate, including control with constant TD (difference between input and output temperature in the heat exchanger on the user side) in systems featuring both the primary and secondary circuits. hot circuit

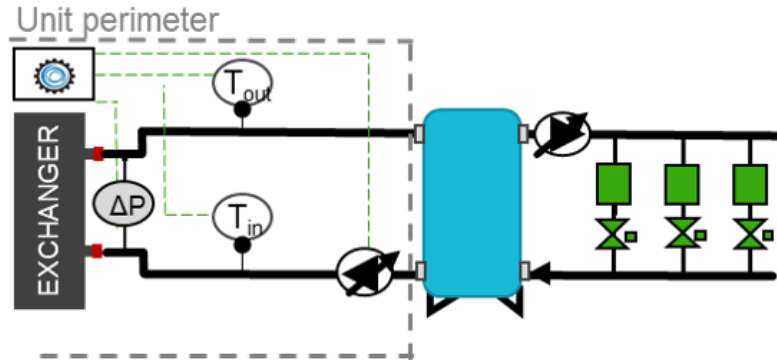

Bluethink solution for variable flow systems - ideal for systems featuring a primary and a secondary circuit physically divided by a heat exchanger or a tank with multiple connections.

flowzer vps with TD-based control includes:

- a differential pressure transducer, installed at the factory at the ends of the user-side heat exchanger of the unit (Δp_e)

The option must be necessarily combined with the Flowzer VP (inverter) and with one of the hydraulic modules that can be selected for the unit. The option is not compatible with the Multilogic version. Please refer to the HYZER solutions for the compatibility between variable flow systems and multi-machine systems.

The unit must include the advanced Bluethink controller and just one heat exchanger on the user side.

The option offers a complete default package to guarantee simple selection, purchasing and commissioning.

flowzer vps with TD-based control offers the following advantages:

- a full package that is easy to install as all the regulating devices are pre-assembled and pre-wired in the unit;
- achieving a complete variable flow system, with maximum energy saving
- the ideal solution to refurbish existing systems where the T difference must be kept constant in the system, especially in comfort applications;

The maximum energy saving is achieved thanks to the advanced algorithm, which prevents hunting by the inverter and balances the pump speed and the recirculation flow rate to a minimum.

The dimensions of the inverter of the unit and of the pump module can be favoured by the low design discharge head of the primary circuit.

The operating principle can be summarized as follows:

- flowzer vps with TD-based control performs smart monitoring of the flow rate in the primary circuit, keeping the T difference constant in the heat exchanger;
- the system controller modulates the pump speed according to the condition detected by the temperature sensors (T) in the system, which are installed at the inlet and outlet of the heat exchanger on the user side;
- the difference in the water temperature (T) and flow rate are inversely proportional, which is why if the T difference is reduced at the same performance level, the water flow exceeds the flow required by the system and the pump speed is reduced in order to save energy;

on the other hand, when the load increases, the T difference increases in the system and the pump speed is increased accordingly.

- The check contributes to reducing/increasing the speed of the pump in the primary circuit until the min./max. flow threshold admitted in the heat exchanger of the unit is exceeded.
- this flow rate is indirectly monitored through the losses detected by the differential pressure transducer Δp_e

The temperature sensors of the system output a 4-20 mA signal.

Further details can be found in the relevant manual.

HFxF HYZER E VFPP function cold circuit

HFxC HYZER E VFPP function hot circuit

The HYZER E VFPP function combines the Multilogic function, which is designed to manage multi-machine systems, with the FLOWZER VFPP control for variable flow systems.

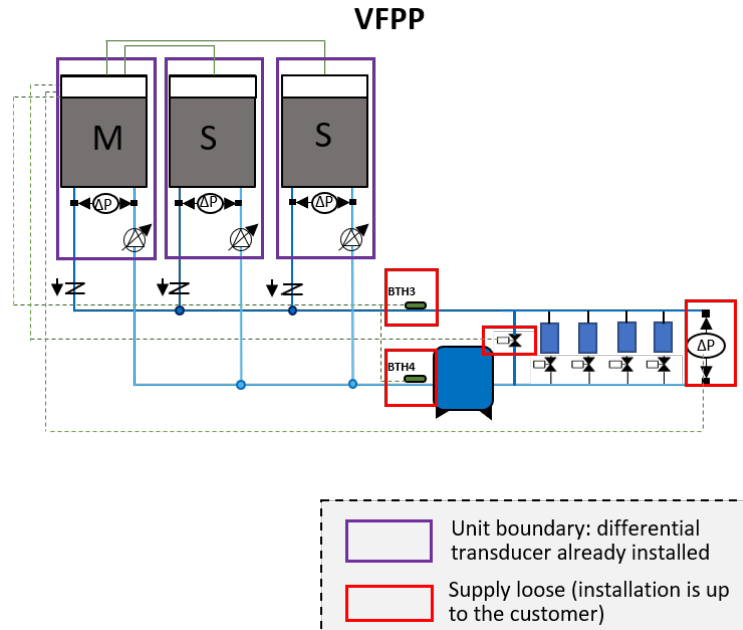

It is obligatory for the option to be combined with the Flowzer VP (inverter) and with one of the hydraulic modules that can be selected for the unit.

The unit must include the advanced Bluethink controller, just one heat exchanger on the user side and a minimum capacity step of 25% or less.

Units operate according to the Master/Slave logic that is typical of a Multilogic system. For additional details, please refer to the FMx option.

The HYZER E function requested with the unit can be:

- **HF0:** HYZER E VFPP function for Slave units;
- **HF2:** HYZER E VFPP function for the Master unit in order to manage up to 2 Slave units;
- **HF6:** HYZER E VFPP function for the Master unit in order to manage up to 6 Slave units.

If you need to connect more than 6 slaves (up to 31), you can ask for a quotation from our sales department.

For the slave units, the accessory requires:

- programming of the unit as slave of a system of machines in Multilogic network

For the master units, the accessory requires:

- programming of the unit as master of a system of machines in Multilogic network
- entering of the parameters necessary for connection with the individual slave units
- installation in the electrical control panel of a network switch to allow the units to be connected in a LAN network.
- the supply of 2 temperature probes to be positioned on the delivery and return manifold for system thermoregulation (supplied with the system - installation and wiring by the customer);
- the supply of two pressure transducers (supplied with the system - installation and wiring by the customer) to be installed near the system terminal that is affected by the highest head losses in the line or in any case in a position where it is possible to measure an adequate pressure value.
- The option also includes the supply of a bypass valve controlled by a 0-10 V signal, which must be selected in function of the system capacity. Please refer to the VBx options for correct selection.

The connection between the master unit and the slave units made with a CAT cable. 5E/UTP (prepared by the customer) with RJ45 connectors. Maximum cable length 100m.

For further details, please refer to the controller manual.

VBxF VFPP bypass valve for HYZER E cold circuit

VBxC VFPP bypass valve for HYZER E hot circuit

The option is supplied with the bypass valve, which is selected according to the system capacity.

This option must be selected with either the "HYZER E VFPP function for Master unit to manage up to 2 Slave units" or "HYZER E VFPP function for Master unit to manage up to 6 Slave units".

	System capacity range**	Quantity	Diameter	Qmax**
	kW	-	in	m ³ /h
S_A	<240	1	2 1/2"	41.3
S_B	240÷335	1	3"	57.6
S_C	335÷570	1	4"	98
S_D	570÷850	1	5"	146.2
S_E	850÷1250	1	6"	215
S_F	1250÷1700	2	2 x 5"	2 x 146.2
S_G	1700÷2500	2	2 x 6"	2 x 215

** values based on a 5 °C temperature difference between the delivery and the return temperature

HSxF HYZER E VPS function cold circuit

HSxC HYZER E VPS function hot circuit

The HYZER E VPS function combines the Multilogic function, which is used to manage multi-machine systems, with the FLOWZER VPS control for variable flow systems.

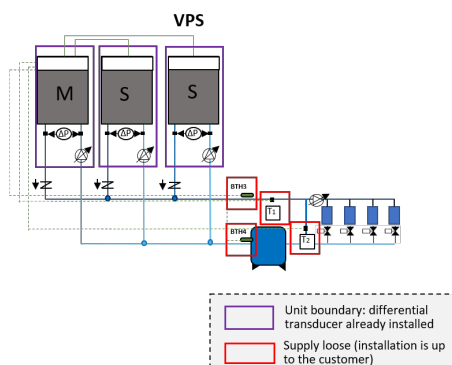

It is obligatory for the option to be combined with the Flowzer VP (inverter) and with one of the hydraulic modules that can be selected for the unit.

The unit must include the advanced Bluethink controller, just one heat exchanger on the user side and a minimum capacity step of 25% or less.

Units operate according to the Master/Slave logic that is typical of a Multilogic system. For additional details, please refer to the FMx option.

VPS control requires the installation on the machine of a differential transducer at the ends of the user-side heat exchanger in order to keep the flow rate in the system within a specific min. value allowed.

For additional details on the FLOWZER VPS logic, please refer to the dedicated FVPS option.

The networked units may be of different types, and the same observations as for the Multilogic option apply:

- if there are both chiller units and heat pumps in the network, the Master unit must obligatorily be one of the HP units;
- if there are both free-cooling and non free-cooling units in the network, the Master unit must obligatorily be one of the free-cooling units.

The HYZER E function requested with the unit can be:

- **HS0:** HYZER E VPS function for Slave units;
- **HS2:** HYZER E VPS function for the Master unit in order to manage up to 2 Slave units;
- **HS6:** HYZER E VPS function for the Master unit in order to manage up to 6 Slave units.

If you need to connect more than 6 slaves (up to 31), you can ask for a quotation from our sales department.

For the slave units, the accessory requires:

- programming of the unit as slave of a system of machines in Multilogic network

For the master units, the accessory requires:

- programming of the unit as master of a system of machines in Multilogic network
- entering of the parameters necessary for connection with the individual slave units
- installation in the electrical control panel of a network switch to allow the units to be connected in a LAN network.
- the supply of 2 temperature probes to be installed on the delivery manifold and on the bypass branch, which are typical of VPS control (supplied with the system - installation and wiring by the customer).

The connection between the master unit and the slave units made with a CAT cable. 5E/UTP (prepared by the customer) with RJ45 connectors. Maximum cable length 100m.

For further details, please refer to the controller manual.

HDxF HYZER E VPS with DT-based control function cold circuit

HDxC HYZER E VPS with DT-based control function hot circuit

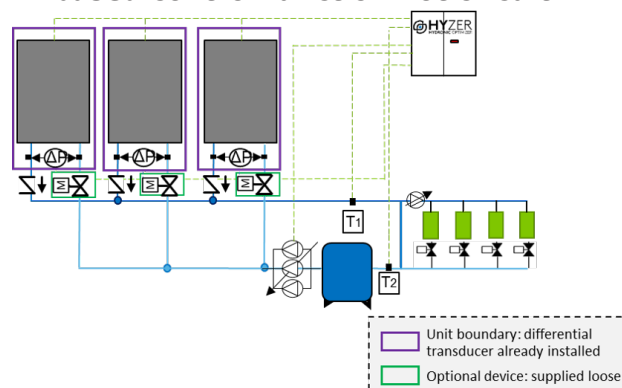

The HYZER E VPS with TD-based control function combines the Multilogic function, which is used to manage multi-machine systems, with the FLOWZER VPS with DT-based control control for variable flow systems.

It is obligatory for the option to be combined with the Flowzer VP (inverter) and with one of the hydraulic modules that can be selected for the unit.

The unit must include the advanced Bluethink controller, just one heat exchanger on the user side and a minimum capacity step of 25% or less.

Units operate according to the Master/Slave logic that is typical of a Multilogic system. For additional details, please refer to the FMx option.

VPS with DT-based control control requires the installation on the machine of a differential transducer at the ends of the user-side heat exchanger in order to keep the flow rate in the system within a specific min. value allowed.

For additional details on the FLOWZER VPS with TD-based control logic, please refer to the dedicated FVPS with DT-based control option.

The networked units may be of different types, and the same observations as for the Multilogic option apply:

- if there are both chiller units and heat pumps in the network, the Master unit must obligatorily be one of the HP units;
- if there are both free-cooling and non free-cooling units in the network, the Master unit must obligatorily be one of the free-cooling units.

The HYZER E function requested with the unit can be:

- **HD0:** HYZER E VPS with TD-based control function for Slave units;
- **HD2:** HYZER E VPS with TD-based control function for the Master unit in order to manage up to 2 Slave units;
- **HD6:** HYZER E VPS with TD-based control function for the Master unit in order to manage up to 6 Slave units.

If you need to connect more than 6 slaves (up to 31), you can ask for a quotation from our sales department.

For the slave units, the accessory requires:

- programming of the unit as slave of a system of machines in Multilogic network

For the master units, the accessory requires:

- programming of the unit as master of a system of machines in Multilogic network
- entering of the parameters necessary for connection with the individual slave units
- installation in the electrical control panel of a network switch to allow the units to be connected in a LAN network.

The connection between the master unit and the slave units made with a CAT cable. 5E/UTP (prepared by the customer) with RJ45 connectors. Maximum cable length 100m.

For further details, please refer to the controller manual.

PVX Variable flow setup for HYZER X

The dedicated HYZER X controller is designed to manage the different units, devices and components that make up a hydronic system.

Systems featuring this controller require that the PVX option be installed at the ends of the user-side heat exchanger of a differential pressure transducer so that the machine is set up for variable flow rate control.

This option is mandatory in all units making up the system.

For additional information on the product HYZER X, please refer to the specific technical catalogue.

VIX Shut-off valves for systems with external pumps for HYZER X

Systems featuring the HYZER X controller enable the selection of the shut-off valve used in systems that have an external pumping unit.

The option is always supplied separately from the unit and is for installation by the customer.

FLMX User-side flow meter for HYZER X

Systems featuring the HYZER X controller enable the selection of the flow meter option to calculate the flow rate and the performances of the units.

The option is supplied with the system for installation on the user side (installation by customer).

Electrical accessories

Some accessories may be incompatible with each other even if not expressly indicated.

CSP Set point compensation depending on external air temperature

For units fitted with this accessory, the set point of the unit is set so that it can vary between two values, a maximum and a minimum, depending on the external air temperature. The compensation ramp and the maximum and minimum values of the set point can be changed by the user.

Unless otherwise specified in the order, the controller will be set to implement a positive compensation logic according to the temperatures shown in the following diagrams:

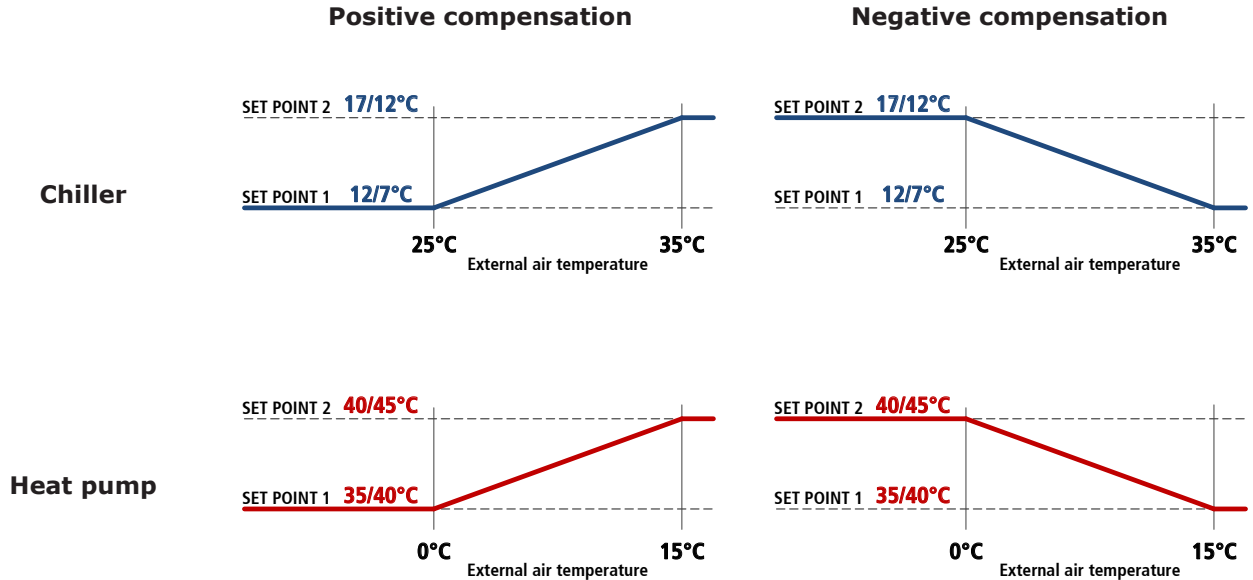

CSTI Enabling for additional heat source

Through a potential free contact, the controller gives the OK signal to an additional heat source to intervene in support of the unit to meet the heat load.

The OK signal to the additional source is given only if the outside air temperature is lower than a settable threshold and if the water temperature set point is not reached within a set time.

CSTS OK signal for substitute heat source

Through a potential free contact, the controller gives the OK signal to an alternative heat source so that it will meet the total heat load demand when the external air temperature is lower than a settable threshold.

For external air temperatures below this threshold, hot water production through the use of the compressors is disabled.

NSS Night Shift System

This accessory is applied to high efficiency /LN version units with speed adjuster or to SLN units.

In the day time slot, which is normally the one with the highest heat load, priority is given to efficiency and therefore the machine works with a fan control curve that maximises the EER. In this time slot, therefore, the unit is a high efficiency low noise machine (equivalent to HE/LN)

In the night time band (or in any case from time band decided by the customer), the priority changes to limiting the noisiness of the machine and therefore the controller carries out an adjustment of the control ramp of the condensing fans, thereby reducing the air flow rate and consequently the noise emission level. So, in this time band, the unit is a super low noise machine (equivalent to SLN).

In any case, if there is a need for additional cooling capacity, the controller will manage the demand, if necessary, by accelerating the fans and keeping condensation within the correct operating limits.

The time slots can be set from the control depending on installation requirements.

When the unit is working in heat pump mode, in order to maximise the COP and to obtain the widest possible operating limits, the control of the unit forces the fans to the maximum speed also during the night time bands.

IACV Automatic circuit breakers

With this accessory, automatic circuit breakers are installed instead of fuses for the protection of auxiliary loads. Also, the same accessory uses automatic circuit breakers with adjustable thermal overload protection to protect the compressors.

LIID Limitation of the current absorbed by digital input

When this accessory is requested, a digital input is prepared in the terminal board to activate the forced capacity reduction of the unit to a set fixed level.

This accessory is useful when there is a need to necessarily limit the power absorbed by the unit as regards particular conditions.

We point out that, in some conditions (for example, during defrosting, oil return cycles or hourly compressor rotation procedures), the controller could force the unit to operate at full capacity for limited periods of time.

RE1P Relay for management of 1 external pump**R1PC Relay for management of 1 external pump hot circuit**

This accessory can be requested for units without pumps and allows a pump outside the machine to be controlled.

R2PF Relay for management of 2 external pumps, cold circuit**R2PC Relay for management of 2 external pumps, hot circuit**

This accessory can be requested for units without pumps and allows two pumps outside the machine to be controlled with a running/stand-by logic by implementing a rotation on the hours of operation.

Dwie pompy są sterowane przez dwa osobne przekaźniki.

RIF Power factor correction to $\cos\varphi \geq 0.95$

With this accessory, an electrical control panel (IP54 protection rating), containing power factor correction capacitors to make the $\cos\varphi$ of the unit greater than or equal to 0.95, is supplied with the unit. The capacitors should be connected (by the customer) to the electrical control panel of the unit in the specially prepared terminal board.

Besides reducing the absorbed reactive power, the use of this accessory also allows the maximum absorbed current to be lowered.

RMMT Maximum and minimum voltage relay

This accessory constantly monitors the voltage value and the unit's power supply phase sequence. If the supply voltage does not fall within the set parameters or there is a phase reversal, an alarm is generated that stops the machine to prevent damage to its main parts

SEDC Double set point from digital input hot circuit

The accessory allows you to preset two different operating set points and manage the change from one to the other through a digital signal.

The set point temperatures must be specified when ordering. For optimization of the unit, reference will be made to the highest set point.

Unless otherwise specified in the order, the controller will be set at the factory with the following temperatures:

- set point 1 at 45°C
- set point 2 at 40°C

SEDF Double set point from digital input cold circuit

The accessory allows you to preset two different operating set points and manage the change from one to the other through a digital signal.

The set point temperatures must be specified when ordering. For optimization of the unit, reference will be made to the lowest set point.

Unless otherwise specified in the order, the controller will be set at the factory with the following temperatures:

- set point 1 at 7°C
- set point 2 at 12°C

SEVC Variable set point with remote signal hot circuit

The accessory allows the set point to be varied continuously between two preset values, a maximum and a minimum, depending on an external signal that can be of the 0-1V, 0-10V or 4-20mA type.

The set point temperatures and the type of signal to use for the adjustment must be specified when ordering. For optimization of the unit, reference will be made to the highest set point.

Unless otherwise specified in the order, the controller will be set at the factory with 0-10V analogue input and with the following temperatures:

- 0V will correspond to a set point of 45°C
- 10V will correspond to a set point of 40°C

SEVF Variable set point with remote signal cold circuit

The accessory allows the set point to be varied continuously between two preset values, a maximum and a minimum, depending on an external signal that can be of the 0-1V, 0-10V or 4-20mA type.

The set point temperatures and the type of signal to use for the adjustment must be specified when ordering. For optimization of the unit, reference will be made to the lowest set point.

Unless otherwise specified in the order, the controller will be set at the factory with 0-10V analogue input and with the following temperatures:

- 0V will correspond to a set point of 7°C
- 10V will correspond to a set point of 12°C

SOFT Electronic soft-starter

The scroll compressors have DOL (Direct On Line) starting and therefore the maximum inrush current I_{MIC} will be 4/5 times its nominal current I_{nom} .

If the unit is equipped with the electronic soft-starter accessory, the starting of each compressor is done with an acceleration ramp that allows the effective value (rms value) of the inrush current of the individual compressor to be lowered.

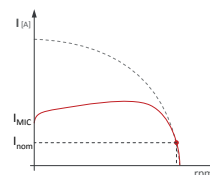
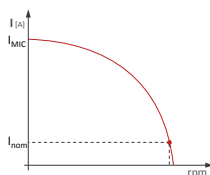

Current trend without accessory soft-starter

Current trend with accessory Electronic soft-starter

If the unit is equipped with accessory "Power factor correction to $\cos\phi \geq 0.95$ ", this last will be electro-mechanically connected only at the end of the acceleration ramp of the soft-starter.

TERM Remote-controlled user terminal panel

This accessory allows the terminal normally situated on the machine to be replicated on a support situated at a distance. It is particularly suitable when the unit is placed in an area that is not easily accessible.

The accessory is supplied loose and is to be installed by the customer at a maximum distance of 120m from the unit. We advise using a cable of the following type: "TECO O.R. FE 2x2xAWG24 SN/ST/PUR".

For this accessory, there is a dedicated serial port.

SV5 Signal for 3-way modulating valve

In the electrical control panel, a 0-10V output is preset to be used to control a 3-way modulating valve inserted on the hot circuit.

If the temperature of the water entering the hot exchanger is too low (for example, after the machine has been stopped for an extended period), through this signal, the controller of the unit will control the valve so as to recirculate part of the flow rate at the outlet and ensure that the unit always works within the operating limits.

The 3-way modulating valve is not included in this accessory, but can be requested as further accessory.

COTW Outgoing water temperature control

With this accessory, outgoing instead of incoming water temperature control is used.

Not available for 2 compressors units (XX.2)

Network accessories

BEET Blueeye® via Ethernet

Blueeye® is a supervision platform that enables remote monitoring of one or more units in the same system interconnected through a network with Modbus protocol.

This accessory features the Blueeye device, as already installed and wired in the unit.

The critical variables to be monitored over time are identified for each connected device. These variables are sampled and saved to the cloud so that they are accessible at all times through a web portal or a mobile APP (available for Android and iOS).

The following options can be selected for connection to the internet:

- a LAN (Ethernet) connection - available in the system;
- a connection to a mobile network - at least 3G. The data SIM card is not included.

Three different types of contracts can be signed.

Blueeye® Cloud Basic:

- to monitor a max. of 20 variables in total over max. 5 units/peripherals;
- to set a min. sampling frequency of 60 seconds.

Blueeye® Cloud Advanced:

- to monitor a max. of 200 variables in total over max. 10 units/peripherals;
- to set a min. sampling frequency of 5 seconds.

Blueeye® Connect:

- To monitor up to 10 units/peripherals.

Subscribing to any of the **Blueeye® Cloud** enables:

- viewing the history of the monitored variables, in the form of both numerical values and graphs;
- downloading the history of variables in CSV format;
- the creation of automatic reports;
- setting notifications (via APP or mail) with settable thresholds for each variable;
- switching the unit ON/OFF remotely;;
- changing the set point remotely;
- selection of SUMMER/WINTER mode remotely (for reversible units only).

The subscription to the **Blueeye® Connect** service offers the advantages below:

- a safe connection (tunnelling) between the user and the remote unit through the Blueeye® portal;
- full access to the remote controller;
- real time monitoring;
- software upgrading.

Blueeye® via Ethernet is only available for units supplied with an advanced controller and does not include any type of service. This service must be purchased separately based on the number of units/devices to be connected and the number of variables to be monitored. In order to connect multiple units to **Blueeye® device, the network switch is required (this accessory is sold separately).**

Units can also be connected to the Blueeye device through the RS485 network featuring a Modbus RTU protocol (for this option, refer to BERS accessory).

For further details, refer to the specific Blueeye® documentation.

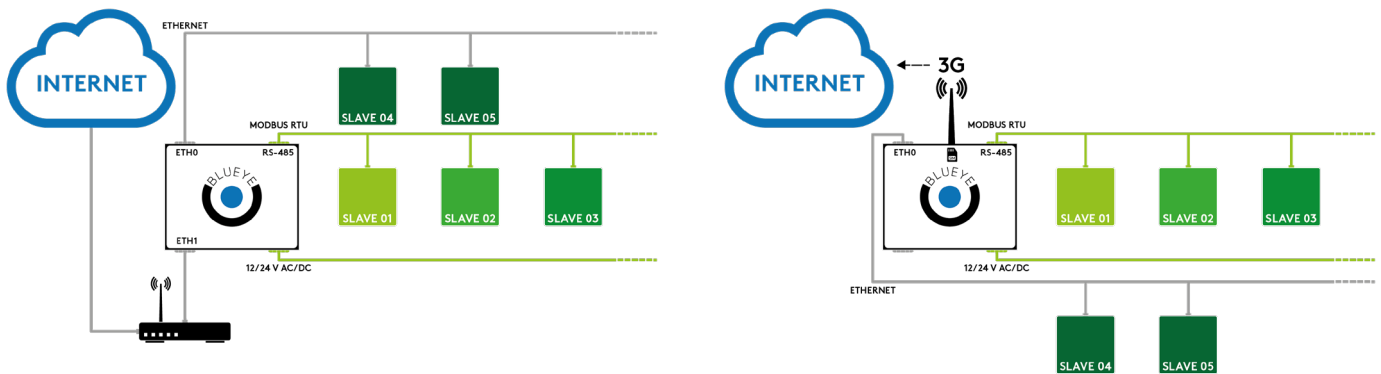

BERS Blueye® via RS485

This accessory requires use of the Blueye device, installed and wired in the unit through a RS485 serial port on the ModBus RTU protocol.

This option requires integration with one contract of the Blueye Cloud series. (Basic or Advanced one)

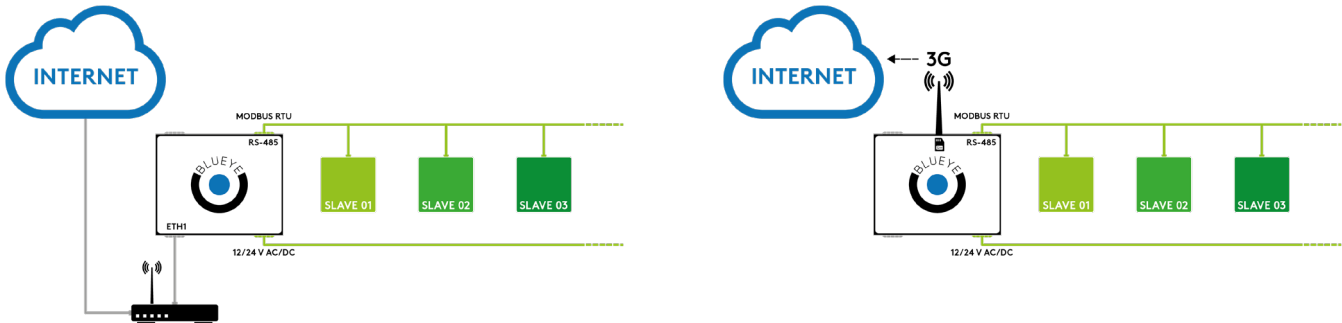

FMx Multilogic Function

The Multilogic function allows management of up to 32 units equipped with advanced Bluethink controller and connected in hydraulic parallel with each other.

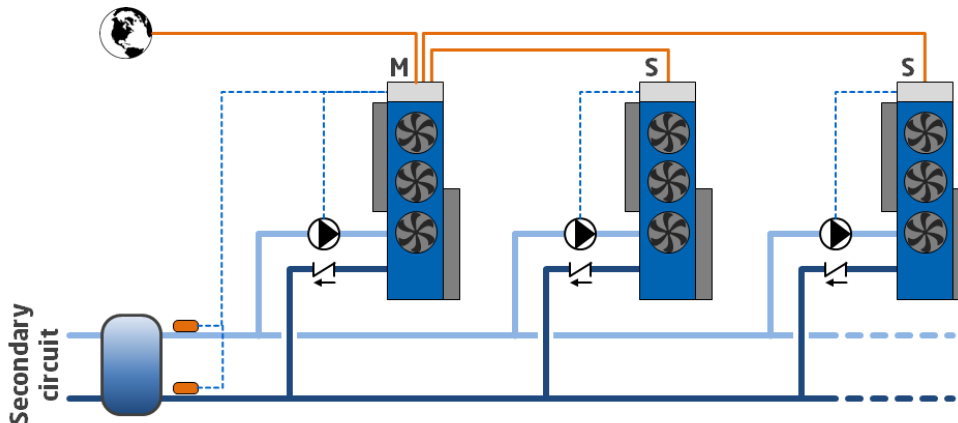

On the basis of the information recorded by the temperature probes installed on the delivery and return manifolds of the system, with the master unit, a capacity request is generated that is distributed among the units connected in the Multilogic network according to settable priority and optimization logics.

If communication between the units fails or if the master is off-line, the slave units can continue to work according to the set thermoregulation parameters.

The connected units can be different from each other, in terms of capacity and set-up, provided the following rule is complied with: if there are both free cooling and non free-cooling units in the Multilogic network, the Master unit must obligatorily be one of the free-cooling units.

The Multilogic function that can be requested with the unit can be:

- **FM0:** Multilogic function for Slave unit
- **FM2:** Multilogic function for Master unit for managing up to 2 Slaves
- **FM6:** Multilogic function for Master unit for managing up to 6 Slaves

If you need to connect more than 6 slaves (up to 31), you can ask for a quotation from our sales department.

For the slave units, the accessory requires:

- programming of the unit as slave of a system of machines in Multilogic network

For the master units, the accessory requires:

- programming of the unit as master of a system of machines in Multilogic network
- entering of the parameters necessary for connection with the individual slave units
- installation in the electrical control panel of a network switch to allow the units to be connected in a LAN network.
- the supply of 2 temperature probes to be positioned on the delivery and return manifold of the system (supplied separately with it, installation and wiring by the customer)

The connection between the master unit and the slave units made with a CAT cable. 5E/UTP (prepared by the customer) with RJ45 connectors. Maximum cable length 100m.

PBA BACnet protocol over IP (Ethernet)

The controller is set for use, in read and write mode, of the BACnet port on IP protocol. By default, the programming gives read-only access to the control of the unit. Enabling of read/write access should be requested when ordering.

SW4P Network switch with 4 ports

The accessory includes installation in DIN rail of a professional 4-port network switch. Requires Blueye via Ethernet.

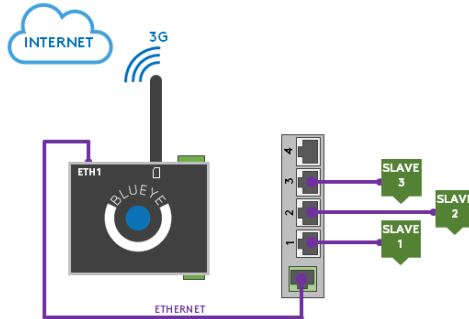

SW8P Network switch with 8 ports

The accessory includes installation in DIN rail of a professional 8-port network switch. Requires Blueye via Ethernet.

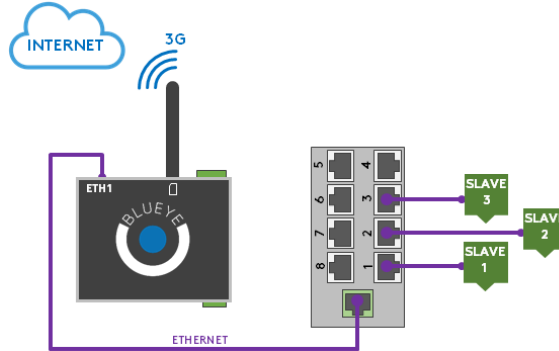

Other accessories

AG Rubber anti-vibration mounts

These allow you to reduce the vibrations transmitted from the unit to the surface it is standing on. Accessory supplied loose.

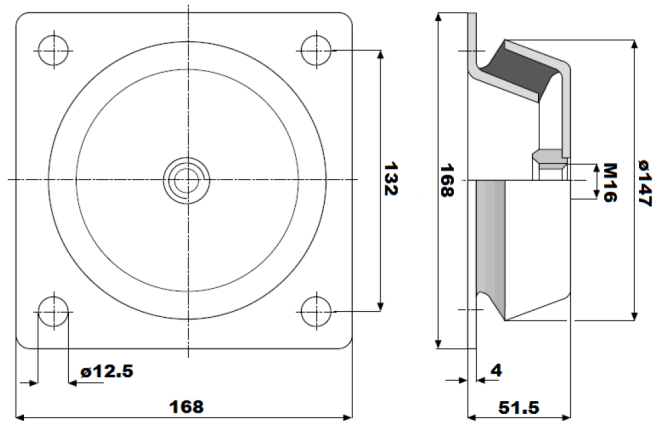

AM Spring anti-vibration mounts

These allow you to reduce the vibrations transmitted from the unit to the surface it is standing on. Accessory supplied loose.

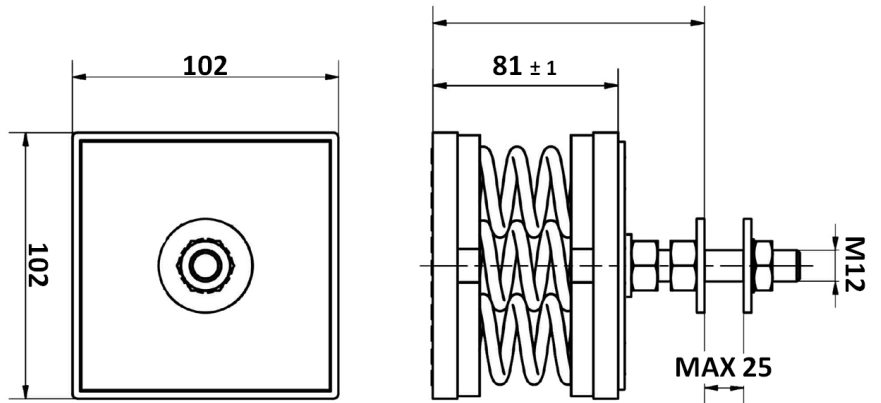

ALPR Pre-painted aluminium coil

This option uses finned pack coils with copper tubes and pre-painted aluminium fins.

ANTC Coil treated with anti-corrosion paints

The treatment is applied exclusively to finned pack coils with copper tubes and aluminium fins and consists of aluminium passivation and coating with a polyurethane base; a double layer of paint, of which the first passivates the aluminium and acts as primer and the second is a polyurethane based surface coating. The product has high resistance to corrosion and all environmental conditions.

The choice of whether or not to treat the exchanger should be made in relation to the environment in which the unit is to be installed and through observation of other structures and machinery with exposed metal surfaces present in the destination environment.

The cross observation criterion is the most valid method of selection currently available without having to carry out preliminary tests or measurements with instruments. The identified reference environments are:

- marine coastal
- industrial
- urban with a high housing density
- rural

KFW Water filter kit

To protect the elements of the hydraulic circuit (in particular, the exchangers), there are Y filters that can stop and settle the particles that are normally present in the water flow and would otherwise settle in the more delicate parts of the hydraulic circuit and damage its heat exchange capacity.

The kit involves the supply of a filter for each exchanger present in the machine.

Installation of the water filter is mandatory even when it is not supplied as an accessory.

Accessory supplied loose.

PREA Unit suitable to be disassembled on site

The unit is delivered so that it can be disassembled easily on site if this makes the installation operations easier.

A unit requested with this option is supplied:

- screwed instead of riveted
- with plugged and not welded pipes
- without refrigerant charge
- untested
- covered by the warranty only if reassembled and screwed together by personnel authorized by the factory

PRAC Steel profiles frames for container shipment

This accessory foresees the mounting of steel profiles frames on the unit for its loading into container.

When this accessory is required it's for the shipping of the unit into container and its loading is mandatory to be done at the factory

RAT Anti-intrusion nets

An arc-welded, painted net (RAL colour 7035) is installed to close off the external openings so as to prevent access to the technical compartment by unauthorized personnel.

**SLCO Skid for shipping in container**

The accessory provides for the installation of a wooden sled for loading and a fixing system inside the container by a strap. The accessory must be used for shipping in container. Loading on containers must be carried out at the factory. The accessory is incompatible with "Packaging in wooden crate".

STL Brackets for transport over long distances

The accessory consists of adding reinforcing bars to the structural metalwork. This allows the strength of the structure to be increased for long distance road transport.

RAV Anti-freeze heater for condensate drip tray

A heating cable, glued to the bottom, can be combined with the condensate drip tray to prevent ice formation at the base of the coil or near the drains.

The heater is controlled by a thermostat and is activated depending on the external air temperature.

Recommended accessory for installations in cold regions.

TECHNICAL SPECIFICATIONS

OMICRON REV S4 HE

			3.2	4.2	5.2	6.2	7.2
Cooling (A35°C; W7°C)							
Refrigeration capacity	(1)	kW	41	48	57	62	71
Total absorbed power	(1)	kW	13	15	18	20	23
EER	(1)		3,17	3,14	3,23	3,18	3,12
Heating (A7°C/87%; W45°C)							
Heating capacity	(2)	kW	44	50	61	66	73
Total absorbed power	(2)	kW	13	31	15	36	18
COP	(2)		3,31	3,28	3,32	3,3	3,27
Cooling + Heating (W7°C; W45°C)							
Refrigeration capacity	(3)	kW	39	46	53	58	67
Heating capacity	(3)	kW	51	59	69	76	87
Total absorbed power	(3)	kW	12	14	16	18	20
EER	(3)		3,26	3,34	3,33	3,29	3,3
COP	(3)		4,25	4,33	4,33	4,29	4,3
TER	(3)		7,51	7,67	7,66	7,58	7,6
Compressors							
Compressors/Circuits		n°/n°	2/2	2/2	2/2	2/2	2/2
Minimum capacity reduction step		%	50%	50%	50%	50%	50%
Refrigerant charge		kg	17	18	24	24	25
Fans							
Quantity		n°	4	4	6	6	6
Total air flow rate (CH)		m3/h	15820	15820	23730	23730	23730
Total air flow rate (HP)		m3/h	15820	15820	23730	23730	23730
Cold-side heat exchanger							
Type			Plates				
Quantity		n°	1	1	1	1	1
Water flow rate (A35°C; W7°C)	(1)	m3/h	7,1	8,3	9,8	10,7	12,2
Head loss (A35°C; W7°C)	(1)	kPa	20	19	19	19	20
Hot-side heat exchanger							
Type			Plates				
Quantity		n°	1	1	1	1	1
Water flow rate (A7°C/87%; W45°C)	(2)	m3/h	7,3	8,3	10,1	11	12
Head loss (A7°C/87%; W45°C)	(2)	kPa	10	11	12	12	13
Hydraulic modules							
Standard pumps, cold circuit (A35°C; W7°C)							
Pump model			P11	P12	P13	P13	P13
Available head (1P)	(1)	kPa	104	116	114	109	103
Available head (2P)	(1)	kPa	96	106	109	103	95
Standard pumps, hot circuit (W7°C; W45°C)							
Pump model			P12	P14	P14	P14	P14
Available head (1R)	(2)	kPa	105	137	142	133	118
Available head (2R)	(2)	kPa	92	120	133	123	105
Noise levels							
Sound power level of basic unit	(4)	dB(A)	86	86	87	88	88
Sound pressure level of basic unit	(5)	dB(A)	54	54	55	56	56
Sound power level of LN version	(4)	dB(A)	84	84	85	86	86
Sound pressure level of LN version	(5)	dB(A)	52	52	53	54	54
Dimensions and weights of basic unit							
Length		mm	2460	2460	2960	2960	2960
Depth		mm	1200	1200	1200	1200	1200
Height		mm	2100	2100	2100	2100	2100
Operating weight of basic version		kg	1099	1115	1307	1308	1352

(CH): when the unit is working in cooling only mode; (HP): when the unit is working in heating only mode

- (1) External air temperature 35°C, user-side heat exchanger water inlet/outlet temperature 12/7°C. Values in accordance with EN 14511.
- (2) Outside air temperature 7°C and input/output water temperature into/from user-side heat exchanger 40/45°C Values compliant with standard EN 14511
- (3) Cold-side exchanger inlet-outlet water temperature 12-7°C; Hot-side exchanger inlet-outlet water temperature 40-45°C Values compliant with standard EN 14511
- (4) Unit operating at nominal operating capacity, without any accessories, with source/side heat exchanger inlet-outlet water temperature 30/35°C and user-side heat exchanger inlet/outlet water temperature 12/7°C. Values obtained from measures taken according to standard ISO 3744.
- (5) Values obtained from the sound power level (conditions: note 4), related to a distance of 10 m from the unit in free field with directivity factor Q=2. Non-binding values See NOISE LEVELS section.

OMICRON REV S4 HE

			8.2	11.2	14.2	16.2
Cooling (A35°C; W7°C)						
Refrigeration capacity	(1)	kW	83	104	135	168
Total absorbed power	(1)	kW	26	33	43	57
EER	(1)		3,17	3,1	3,16	2,93
Heating (A7°C/87%; W45°C)						
Heating capacity	(2)	kW	87	105	141	175
Total absorbed power	(2)	kW	54	20	60	22
COP	(2)		3,29	3,25	3,22	3,19
Cooling + Heating (W7°C; W45°C)						
Refrigeration capacity	(3)	kW	79	102	126	164
Heating capacity	(3)	kW	102	131	164	213
Total absorbed power	(3)	kW	24	29	37	50
EER	(3)		3,32	3,45	3,37	3,31
COP	(3)		4,31	4,45	4,37	4,31
TER	(3)		7,63	7,9	7,74	7,62
Compressors						
Compressors/Circuits		n°/n°	2/2	2/2	2/2	2/2
Minimum capacity reduction step		%	50%	50%	50%	50%
Refrigerant charge		kg	35	36	50	54
Fans						
Quantity		n°	2	2	4	4
Total air flow rate (CH)		m3/h	32000	32000	64000	64000
Total air flow rate (HP)		m3/h	32000	32000	64000	64000
Cold-side heat exchanger						
Type			Plates			
Quantity		n°	1	1	1	1
Water flow rate (A35°C; W7°C)	(1)	m3/h	14,4	17,9	23,3	29
Head loss (A35°C; W7°C)	(1)	kPa	21	22	22	24
Hot-side heat exchanger						
Type			Plates			
Quantity		n°	1	1	1	1
Water flow rate (A7°C/87%; W45°C)	(2)	m3/h	14,4	17,5	23,5	29,2
Head loss (A7°C/87%; W45°C)	(2)	kPa	13	14	15	16
Hydraulic modules						
Standard pumps, cold circuit (A35°C; W7°C)						
Pump model			P16	P16	P1	P1
Available head (1P)	(1)	kPa	105	90	111	96
Available head (2P)	(1)	kPa	101	85	107	90
Standard pumps, hot circuit (W7°C; W45°C)						
Pump model			P17	P17	P1	P2
Available head (1R)	(2)	kPa	135	104	87	107
Available head (2R)	(2)	kPa	129	95	80	95
Noise levels						
Sound power level of basic unit	(4)	dB(A)	89	90	91	91
Sound pressure level of basic unit	(5)	dB(A)	57	58	59	59
Sound power level of LN version	(4)	dB(A)	87	88	89	89
Sound pressure level of LN version	(5)	dB(A)	55	56	57	57
Dimensions and weights of basic unit						
Length		mm	4172	4172	5170	5170
Depth		mm	1200	1200	1200	1200
Height		mm	2100	2100	2100	2100
Operating weight of basic version		kg	1614	1682	2013	2204

(CH): when the unit is working in cooling only mode; (HP): when the unit is working in heating only mode

- (1) External air temperature 35°C, user-side heat exchanger water inlet/outlet temperature 12/7°C. Values in accordance with EN 14511.
- (2) Outside air temperature 7°C and input/output water temperature into/from user-side heat exchanger 40/45°C Values compliant with standard EN 14511
- (3) Cold-side exchanger inlet-outlet water temperature 12-7°C; Hot-side exchanger inlet-outlet water temperature 40-45°C Values compliant with standard EN 14511
- (4) Unit operating at nominal operating capacity, without any accessories, with source/side heat exchanger inlet-outlet water temperature 30/35°C and user-side heat exchanger inlet/outlet water temperature 12/7°C. Values obtained from measures taken according to standard ISO 3744.
- (5) Values obtained from the sound power level (conditions: note 4), related to a distance of 10 m from the unit in free field with directivity factor Q=2. Non-binding values See NOISE LEVELS section.

OMICRON REV S4 HE

			10.4	12.4	17.4	19.4	21.4	25.4
Cooling (A35°C; W7°C)								
Refrigeration capacity	(1)	kW	97	109	171	193	212	249
Total absorbed power	(1)	kW	31	37	54	62	71	77
EER	(1)		3,13	2,96	3,16	3,11	2,98	3,25
Heating (A7°C/87%; W45°C)								
Heating capacity	(2)	kW	100	114	179	197	217	259
Total absorbed power	(2)	kW	31	36	54	61	67	80
COP	(2)		3,22	3,17	3,31	3,26	3,24	3,25
Cooling + Heating (W7°C; W45°C)								
Refrigeration capacity	(3)	kW	89	103	157	177	197	226
Heating capacity	(3)	kW	117	136	204	231	258	295
Total absorbed power	(3)	kW	28	33	48	55	61	68
EER	(3)		3,21	3,12	3,26	3,23	3,22	3,31
COP	(3)		4,2	4,11	4,26	4,22	4,21	4,31
TER	(3)		7,41	7,24	7,52	7,46	7,43	7,62
Compressors								
Compressors/Circuits		n°/n°	4/2	4/2	4/2	4/2	4/2	4/2
Minimum capacity reduction step		%	25%	25%	25%	25%	25%	25%
Refrigerant charge		kg	27	27	48	49	49	86
Fans								
Quantity		n°	2	2	4	4	4	6
Total air flow rate (CH)		m3/h	40000	40000	80000	80000	80000	120000
Total air flow rate (HP)		m3/h	40000	40000	80000	80000	80000	120000
Cold-side heat exchanger								
Type			Plates					
Quantity		n°	1	1	1	1	1	1
Water flow rate (A35°C; W7°C)	(1)	m3/h	16,8	18,9	29,4	33,3	36,6	42,9
Head loss (A35°C; W7°C)	(1)	kPa	23	29	27	34	40	23
Hot-side heat exchanger								
Type			Plates					
Quantity		n°	1	1	1	1	1	1
Water flow rate (A7°C/87%; W45°C)	(2)	m3/h	17,1	19,6	30,7	33,8	37,3	44,5
Head loss (A7°C/87%; W45°C)	(2)	kPa	24	31	29	28	34	16
Hydraulic modules								
Standard pumps, cold circuit (A35°C; W7°C)								
Pump model			P1	P1	P1	P2	P2	P3
Available head (1P)	(1)	kPa	128	116	89	134	110	134
Available head (2P)	(1)	kPa	124	110	74	115	88	119
Standard pumps, hot circuit (W7°C; W45°C)								
Pump model			P1	P1	P2	P3	P3	P3
Available head (1R)	(2)	kPa	141	126	149	161	147	160
Available head (2R)	(2)	kPa	136	120	133	153	137	154
Noise levels								
Sound power level of basic unit	(4)	dB(A)	85	85	86	88	89	90
Sound pressure level of basic unit	(5)	dB(A)	53	53	54	56	57	58
Sound power level of LN version	(4)	dB(A)	81	81	82	84	85	86
Sound pressure level of LN version	(5)	dB(A)	49	49	50	52	53	54
Dimensions and weights of basic unit								
Length		mm	2297	2297	2297	2297	2297	5002
Depth		mm	2256	2256	2256	2256	2256	2256
Height		mm	2443	2443	2443	2443	2443	2443
Operating weight of basic version		kg	1606	1622	1958	1985	2002	3496

(CH): when the unit is working in cooling only mode; (HP): when the unit is working in heating only mode

- (1) External air temperature 35°C, user-side heat exchanger water inlet/outlet temperature 12/7°C. Values in accordance with EN 14511.
- (2) Outside air temperature 7°C and input/output water temperature into/from user-side heat exchanger 40/45°C Values compliant with standard EN 14511
- (3) Cold-side exchanger inlet-outlet water temperature 12-7°C; Hot-side exchanger inlet-outlet water temperature 40-45°C Values compliant with standard EN 14511
- (4) Unit operating at rated capacity, with no accessories of any kind - external air temperature 35°C and water input/output temperature from/to heat exchanger and user equal to 12/7°C. Values taken by measurements made in accordance with standard ISO 3744 and the Eurovent certification programme, where applicable. Binding values See NOISE LEVELS section.
- (5) Values obtained from the sound power level (conditions: note 4), related to a distance of 10 m from the unit in free field with directivity factor Q=2. Non-binding values See NOISE LEVELS section.

OMICRON REV S4 HE

			29.4	32.4	36.4	40.4	43.4
Cooling (A35°C; W7°C)							
Refrigeration capacity	(1)	kW	273	319	355	402	439
Total absorbed power	(1)	kW	86	101	113	130	147
EER	(1)		3,16	3,17	3,14	3,1	2,98
Heating (A7°C/87%; W45°C)							
Heating capacity	(2)	kW	286	323	359	400	435
Total absorbed power	(2)	kW	89	100	112	124	136
COP	(2)		3,23	3,23	3,21	3,23	3,21
Cooling + Heating (W7°C; W45°C)							
Refrigeration capacity	(3)	kW	252	292	326	374	417
Heating capacity	(3)	kW	328	380	427	487	545
Total absorbed power	(3)	kW	77	88	101	114	129
EER	(3)		3,29	3,33	3,23	3,27	3,24
COP	(3)		4,29	4,33	4,23	4,27	4,23
TER	(3)		7,58	7,65	7,47	7,54	7,47
Compressors							
Compressors/Circuits		n°/n°	4/2	4/2	4/2	4/2	4/2
Minimum capacity reduction step		%	25%	25%	25%	25%	25%
Refrigerant charge		kg	87	103	103	117	117
Fans							
Quantity		n°	6	8	8	8	8
Total air flow rate (CH)		m3/h	120000	160000	160000	160000	160000
Total air flow rate (HP)		m3/h	120000	160000	160000	160000	160000
Cold-side heat exchanger							
Type			Plates				
Quantity		n°	1	1	1	1	1
Water flow rate (A35°C; W7°C)	(1)	m3/h	47	55	61,2	69,3	75,6
Head loss (A35°C; W7°C)	(1)	kPa	27	25	30	32	38
Hot-side heat exchanger							
Type			Plates				
Quantity		n°	1	1	1	1	1
Water flow rate (A7°C/87%; W45°C)	(2)	m3/h	49,1	55,5	61,8	68,7	74,8
Head loss (A7°C/87%; W45°C)	(2)	kPa	16	16	20	19	22
Hydraulic modules							
Standard pumps, cold circuit (A35°C; W7°C)							
Pump model			P3	P4	P4	P4	P4
Available head (1P)	(1)	kPa	122	144	129	111	92
Available head (2P)	(1)	kPa	105	135	117	96	75
Standard pumps, hot circuit (W7°C; W45°C)							
Pump model			P3	P4	P5	P5	P6
Available head (1R)	(2)	kPa	150	151	182	175	198
Available head (2R)	(2)	kPa	143	141	169	159	181
Noise levels							
Sound power level of basic unit	(4)	dB(A)	91	92	93	93	93
Sound pressure level of basic unit	(5)	dB(A)	59	60	61	61	61
Sound power level of LN version	(4)	dB(A)	87	88	89	89	89
Sound pressure level of LN version	(5)	dB(A)	55	56	57	57	57
Dimensions and weights of basic unit							
Length		mm	5002	5002	5002	5002	5002
Depth		mm	2256	2256	2256	2256	2256
Height		mm	2443	2443	2443	2443	2443
Operating weight of basic version		kg	3524	3866	3912	3996	4056

(CH): when the unit is working in cooling only mode; (HP): when the unit is working in heating only mode

- (1) External air temperature 35°C, user-side heat exchanger water inlet/outlet temperature 12/7°C. Values in accordance with EN 14511.
- (2) Outside air temperature 7°C and input/output water temperature into/from user-side heat exchanger 40/45°C Values compliant with standard EN 14511
- (3) Cold-side exchanger inlet-outlet water temperature 12-7°C; Hot-side exchanger inlet-outlet water temperature 40-45°C Values compliant with standard EN 14511
- (4) Unit operating at rated capacity, with no accessories of any kind - external air temperature 35°C and water input/output temperature from/to heat exchanger and user equal to 12/7°C. Values taken by measurements made in accordance with standard ISO 3744 and the Eurovent certification programme, where applicable. Binding values See NOISE LEVELS section.
- (5) Values obtained from the sound power level (conditions: note 4), related to a distance of 10 m from the unit in free field with directivity factor Q=2. Non-binding values See NOISE LEVELS section.

OMICRON REV S4 HE

			51.6	60.6	68.8	75.8	82.8
Cooling (A35°C; W7°C)							
Refrigeration capacity	(1)	kW	522	642	693	779	856
Total absorbed power	(1)	kW	171	223	228	263	297
EER	(1)		3,05	2,88	3,04	2,96	2,89
Heating (A7°C/87%; W45°C)							
Heating capacity	(2)	kW	541	660	722	798	881
Total absorbed power	(2)	kW	173	209	230	255	283
COP	(2)		3,13	3,15	3,14	3,13	3,12
Cooling + Heating (W7°C; W45°C)							
Refrigeration capacity	(3)	kW	479	613	639	723	805
Heating capacity	(3)	kW	633	808	844	957	1070
Total absorbed power	(3)	kW	156	197	208	239	270
EER	(3)		3,06	3,11	3,07	3,03	2,98
COP	(3)		4,05	4,09	4,06	4,01	3,96
TER	(3)		7,11	7,2	7,14	7,03	6,95
Compressors							
Compressors/Circuits		n°/n°	6/3	6/3	8/4	8/4	8/4
Minimum capacity reduction step		%	17%	17%	12%	12%	12%
Refrigerant charge		kg	166	191	238	261	271
Fans							
Quantity		n°	12	12	16	16	16
Total air flow rate (CH)		m3/h	240000	240000	320000	320000	320000
Total air flow rate (HP)		m3/h	240000	240000	320000	320000	320000
Cold-side heat exchanger							
Type			Shell & tube				
Quantity		n°	1	1	1	1	1
Water flow rate (A35°C; W7°C)	(1)	m3/h	89,9	110,5	119,3	134,1	147,3
Head loss (A35°C; W7°C)	(1)	kPa	41	39	38	55	37
Hot-side heat exchanger							
Type			Shell & tube				
Quantity		n°	1	1	1	1	1
Water flow rate (A7°C/87%; W45°C)	(2)	m3/h	93	113,4	124,1	137,1	151,5
Head loss (A7°C/87%; W45°C)	(2)	kPa	30	21	25	29	44
Hydraulic modules							
Standard pumps, cold circuit (A35°C; W7°C)							
Pump model			P7	P8	P9	P9	P9
Available head (1P)	(1)	kPa	128	137	153	119	119
Available head (2P)	(1)	kPa	101	97	141	104	102
Standard pumps, hot circuit (W7°C; W45°C)							
Pump model			P9	P9	P9	P10	P10
Available head (1R)	(2)	kPa	193	179	158	180	167
Available head (2R)	(2)	kPa	186	169	146	172	158
Noise levels							
Sound power level of basic unit	(4)	dB(A)	94	95	96	96	97
Sound pressure level of basic unit	(5)	dB(A)	62	63	63	63	64
Sound power level of LN version	(4)	dB(A)	90	91	92	92	93
Sound pressure level of LN version	(5)	dB(A)	58	59	59	59	60
Dimensions and weights of basic unit							
Length		mm	7383	7383	9183	9183	9183
Depth		mm	2256	2256	2256	2256	2256
Height		mm	2443	2443	2443	2443	2443
Operating weight of basic version		kg	6849	7443	9177	9300	9420

(CH): when the unit is working in cooling only mode; (HP): when the unit is working in heating only mode

- (1) External air temperature 35°C, user-side heat exchanger water inlet/outlet temperature 12/7°C. Values in accordance with EN 14511.
- (2) Outside air temperature 7°C and input/output water temperature into/from user-side heat exchanger 40/45°C Values compliant with standard EN 14511
- (3) Cold-side exchanger inlet-outlet water temperature 12-7°C; Hot-side exchanger inlet-outlet water temperature 40-45°C Values compliant with standard EN 14511
- (4) Unit operating at rated capacity, with no accessories of any kind - external air temperature 35°C and water input/output temperature from/to heat exchanger and user equal to 12/7°C. Values taken by measurements made in accordance with standard ISO 3744 and the Eurovent certification programme, where applicable. Binding values See NOISE LEVELS section.
- (5) Values obtained from the sound power level (conditions: note 4), related to a distance of 10 m from the unit in free field with directivity factor Q=2. Non-binding values See NOISE LEVELS section.

OMICRON REV S4 SLN

			3.2	4.2	5.2	6.2	7.2
Cooling (A35°C; W7°C)							
Refrigeration capacity	(1)	kW	40	46	53	60	67
Total absorbed power	(1)	kW	13	16	18	20	23
EER	(1)		2,99	2,89	3,01	2,98	2,89
Heating (A7°C/87%; W45°C)							
Heating capacity	(2)	kW	44	50	61	66	73
Total absorbed power	(2)	kW	13	15	18	20	22
COP	(2)		3,31	3,28	3,32	3,3	3,27
Cooling + Heating (W7°C; W45°C)							
Refrigeration capacity	(3)	kW	39	46	53	58	67
Heating capacity	(3)	kW	51	59	69	76	87
Total absorbed power	(3)	kW	12	14	16	18	20
EER	(3)		3,26	3,34	3,33	3,29	3,3
COP	(3)		4,25	4,33	4,33	4,29	4,3
TER	(3)		7,51	7,67	7,66	7,58	7,6
Compressors							
Compressors/Circuits		n°/n°	2/2	2/2	2/2	2/2	2/2
Minimum capacity reduction step		%	50%	50%	50%	50%	50%
Refrigerant charge		kg	17	18	24	24	25
Fans							
Quantity		n°	4	4	6	6	6
Total air flow rate (CH)		m3/h	15820	15820	23730	23730	23730
Total air flow rate (HP)		m3/h	22600	22600	33900	33900	33900
Cold-side heat exchanger							
Type			Plates				
Quantity		n°	1	1	1	1	1
Water flow rate (A35°C; W7°C)	(1)	m3/h	6,8	7,9	9,2	10,3	11,6
Head loss (A35°C; W7°C)	(1)	kPa	23	26	24	25	25
Hot-side heat exchanger							
Type			Plates				
Quantity		n°	1	1	1	1	1
Water flow rate (A7°C/87%; W45°C)	(2)	m3/h	7,3	8,3	10,1	11	12
Head loss (A7°C/87%; W45°C)	(2)	kPa	10	11	12	12	13
Hydraulic modules							
Standard pumps, cold circuit (A35°C; W7°C)							
Pump model			P11	P12	P13	P13	P13
Available head (1P)		kPa	111	127	118	114	108
Available head (2P)		kPa	104	118	113	108	101
Standard pumps, hot circuit (W7; W45°C)							
Pump model			P12	P14	P14	P14	P14
Available head (1R)		kPa	105	137	142	133	118
Available head (2R)		kPa	92	120	133	123	105
Noise levels							
Sound power level of SLN unit	(4)	dB(A)	81	81	82	83	83
Sound pressure level of SLN unit	(5)	dB(A)	49	49	50	51	51
Dimensions and weights of basic unit							
Length		mm	2460	2460	2960	2960	2960
Depth		mm	1200	1200	1200	1200	1200
Height		mm	2100	2100	2100	2100	2100
Operating weight of basic version		kg	1099	1115	1307	1308	1352

(CH): when the unit is working in cooling only mode; (HP): when the unit is working in heating only mode

- (1) External air temperature 35°C, user-side heat exchanger water inlet/outlet temperature 12/7°C. Values in accordance with EN 14511.
- (2) Outside air temperature 7°C and input/output water temperature into/from user-side heat exchanger 40/45°C Values compliant with standard EN 14511
- (3) Cold-side exchanger inlet-outlet water temperature 12-7°C; Hot-side exchanger inlet-outlet water temperature 40-45°C Values compliant with standard EN 14511
- (4) Unit operating at nominal operating capacity, without any accessories, with source/side heat exchanger inlet-outlet water temperature 30/35°C and user-side heat exchanger inlet/outlet water temperature 12/7°C. Values obtained from measures taken according to standard ISO 3744.
- (5) Values obtained from the sound power level (conditions: note 4), related to a distance of 10 m from the unit in free field with directivity factor Q=2. Non-binding values See NOISE LEVELS section.

OMICRON REV S4 SLN

			8.2	11.2	14.2	16.2
Cooling (A35°C; W7°C)						
Refrigeration capacity	(1)	kW	78	98	128	158
Total absorbed power	(1)	kW	27	35	42	58
EER	(1)		2,94	2,79	3,03	2,74
Heating (A7°C/87%; W45°C)						
Heating capacity	(2)	kW	87	105	141	175
Total absorbed power	(2)	kW	26	32	44	55
COP	(2)		3,29	3,25	3,22	3,19
Cooling + Heating (W7°C; W45°C)						
Refrigeration capacity	(3)	kW	79	102	126	164
Heating capacity	(3)	kW	102	131	164	213
Total absorbed power	(3)	kW	24	29	37	50
EER	(3)		3,32	3,45	3,37	3,31
COP	(3)		4,31	4,45	4,37	4,31
TER	(3)		7,63	7,9	7,74	7,62
Compressors						
Compressors/Circuits		n°/n°	2/2	2/2	2/2	2/2
Minimum capacity reduction step		%	50%	50%	50%	50%
Refrigerant charge		kg	35	36	50	54
Fans						
Quantity		n°	2	2	4	4
Total air flow rate (CH)		m3/h	32000	32000	64000	64000
Total air flow rate (HP)		m3/h	40000	40000	80000	80000
Cold-side heat exchanger						
Type			Plates			
Quantity		n°	1	1	1	1
Water flow rate (A35°C; W7°C)	(1)	m3/h	13,5	16,9	22,1	27,3
Head loss (A35°C; W7°C)	(1)	kPa	26	26	28	27
Hot-side heat exchanger						
Type			Plates			
Quantity		n°	1	1	1	1
Water flow rate (A7°C/87%; W45°C)	(2)	m3/h	14,6	17,6	23,5	29,2
Head loss (A7°C/87%; W45°C)	(2)	kPa	13	14	15	16
Hydraulic modules						
Standard pumps, cold circuit (A35°C; W7°C)						
Pump model			P16	P16	P1	P1
Available head (1P)		kPa	109	98	117	107
Available head (2P)		kPa	106	93	113	102
Standard pumps, hot circuit (W7; W45°C)						
Pump model			P17	P17	P1	P2
Available head (1R)		kPa	135	104	87	107
Available head (2R)		kPa	129	95	80	95
Noise levels						
Sound power level of SLN unit	(4)	dB(A)	84	85	86	86
Sound pressure level of SLN unit	(5)	dB(A)	52	53	54	54
Dimensions and weights of basic unit						
Length		mm	4172	4172	5170	5170
Depth		mm	1200	1200	1200	1200
Height		mm	2100	2100	2100	2100
Operating weight of basic version		kg	1614	1682	2013	2204

(CH): when the unit is working in cooling only mode; (HP): when the unit is working in heating only mode

- (1) External air temperature 35°C, user-side heat exchanger water inlet/outlet temperature 12/7°C. Values in accordance with EN 14511.
- (2) Outside air temperature 7°C and input/output water temperature into/from user-side heat exchanger 40/45°C Values compliant with standard EN 14511
- (3) Cold-side exchanger inlet-outlet water temperature 12-7°C; Hot-side exchanger inlet-outlet water temperature 40-45°C Values compliant with standard EN 14511
- (4) Unit operating at nominal operating capacity, without any accessories, with source/side heat exchanger inlet-outlet water temperature 30/35°C and user-side heat exchanger inlet/outlet water temperature 12/7°C. Values obtained from measures taken according to standard ISO 3744.
- (5) Values obtained from the sound power level (conditions: note 4), related to a distance of 10 m from the unit in free field with directivity factor Q=2. Non-binding values See NOISE LEVELS section.

OMICRON REV S4 SLN

			10.4	12.4	17.4	19.4	21.4	25.4
Cooling (A35°C; W7°C)								
Refrigeration capacity	(1)	kW	93	103	165	184	200	241
Total absorbed power	(1)	kW	32	39	54	64	74	77
EER	(1)		2,91	2,64	3,04	2,89	2,71	3,11
Heating (A7°C/87%; W45°C)								
Heating capacity	(2)	kW	100	114	179	197	217	259
Total absorbed power	(2)	kW	31	36	54	61	67	80
COP	(2)		3,22	3,17	3,31	3,26	3,24	3,25
Cooling + Heating (W7°C; W45°C)								
Refrigeration capacity	(3)	kW	89	103	157	177	197	226
Heating capacity	(3)	kW	117	136	204	231	258	295
Total absorbed power	(3)	kW	28	33	48	55	61	68
EER	(3)		3,21	3,12	3,26	3,23	3,22	3,31
COP	(3)		4,2	4,11	4,26	4,22	4,21	4,31
TER	(3)		7,41	7,24	7,52	7,46	7,43	7,62
Compressors								
Compressors/Circuits		n°/n°	4/2	4/2	4/2	4/2	4/2	4/2
Minimum capacity reduction step		%	25%	25%	25%	25%	25%	25%
Refrigerant charge		kg	27	27	48	49	49	86
Fans								
Quantity		n°	2	2	4	4	4	6
Total air flow rate (CH)		m3/h	32000	32000	64000	64000	64000	96000
Total air flow rate (HP)		m3/h	40000	40000	80000	80000	80000	120000
Cold-side heat exchanger								
Type			Plates					
Quantity		n°	1	1	1	1	1	1
Water flow rate (A35°C; W7°C)	(1)	m3/h	16	17,8	28,4	31,8	34,5	41,5
Head loss (A35°C; W7°C)	(1)	kPa	21	25	26	31	36	22
Hot-side heat exchanger								
Type			Plates					
Quantity		n°	1	1	1	1	1	1
Water flow rate (A7°C/87%; W45°C)	(2)	m3/h	17,1	19,6	30,7	33,8	37,3	44,5
Head loss (A7°C/87%; W45°C)	(2)	kPa	24	31	29	28	34	16
Hydraulic modules								
Standard pumps, cold circuit (A35°C; W7°C)								
Pump model			P1	P1	P1	P2	P2	P3
Available head (1P)		kPa	132	123	96	143	124	138
Available head (2P)		kPa	128	118	82	126	104	125
Standard pumps, hot circuit (W7; W45°C)								
Pump model			P1	P1	P2	P3	P3	P3
Available head (1R)		kPa	141	126	149	161	147	160
Available head (2R)		kPa	136	120	133	153	137	154
Noise levels								
Sound power level of SLN unit	(4)	dB(A)	78	78	79	81	82	83
Sound pressure level of SLN unit	(5)	dB(A)	46	46	47	49	50	51
Dimensions and weights of basic unit								
Length		mm	2297	2297	2297	2297	2297	5002
Depth		mm	2256	2256	2256	2256	2256	2256
Height		mm	2443	2443	2443	2443	2443	2443
Operating weight of basic version		kg	1796	1812	2149	2175	2191	3670

(CH): when the unit is working in cooling only mode; (HP): when the unit is working in heating only mode

- (1) External air temperature 35°C, user-side heat exchanger water inlet/outlet temperature 12/7°C. Values in accordance with EN 14511.
- (2) Outside air temperature 7°C and input/output water temperature into/from user-side heat exchanger 40/45°C Values compliant with standard EN 14511
- (3) Cold-side exchanger inlet-outlet water temperature 12-7°C; Hot-side exchanger inlet-outlet water temperature 40-45°C Values compliant with standard EN 14511
- (4) Unit operating at rated capacity, with no accessories of any kind - external air temperature 35°C and water input/output temperature from/to heat exchanger and user equal to 12/7°C. Values taken by measurements made in accordance with standard ISO 3744 and the Eurovent certification programme, where applicable. Binding values See NOISE LEVELS section.
- (5) Values obtained from the sound power level (conditions: note 4), related to a distance of 10 m from the unit in free field with directivity factor Q=2. Non-binding values See NOISE LEVELS section.

OMICRON REV S4 SLN

			29.4	32.4	36.4	40.4	43.4
Cooling (A35°C; W7°C)							
Refrigeration capacity	(1)	kW	265	308	341	385	415
Total absorbed power	(1)	kW	88	101	115	133	153
EER	(1)		3	3,05	2,96	2,89	2,72
Heating (A7°C/87%; W45°C)							
Heating capacity	(2)	kW	286	323	359	400	435
Total absorbed power	(2)	kW	89	100	112	124	136
COP	(2)		3,23	3,23	3,21	3,23	3,21
Cooling + Heating (W7°C; W45°C)							
Refrigeration capacity	(3)	kW	252	292	326	374	417
Heating capacity	(3)	kW	328	380	427	487	545
Total absorbed power	(3)	kW	77	88	101	114	129
EER	(3)		3,29	3,33	3,23	3,27	3,24
COP	(3)		4,29	4,33	4,23	4,27	4,23
TER	(3)		7,58	7,65	7,47	7,54	7,47
Compressors							
Compressors/Circuits		n°/n°	4/2	4/2	4/2	4/2	4/2
Minimum capacity reduction step		%	25%	25%	25%	25%	25%
Refrigerant charge		kg	87	103	103	117	117
Fans							
Quantity		n°	6	8	8	8	8
Total air flow rate (CH)		m3/h	96000	128000	128000	128000	128000
Total air flow rate (HP)		m3/h	120000	160000	160000	160000	160000
Cold-side heat exchanger							
Type			Plates				
Quantity		n°	1	1	1	1	1
Water flow rate (A35°C; W7°C)	(1)	m3/h	45,6	53	58,6	66,2	71,5
Head loss (A35°C; W7°C)	(1)	kPa	26	24	28	30	34
Hot-side heat exchanger							
Type			Plates				
Quantity		n°	1	1	1	1	1
Water flow rate (A7°C/87%; W45°C)	(2)	m3/h	49,1	55,5	61,8	68,7	74,8
Head loss (A7°C/87%; W45°C)	(2)	kPa	16	16	20	19	22
Hydraulic modules							
Standard pumps, cold circuit (A35°C; W7°C)							
Pump model			P3	P4	P4	P4	P4
Available head (1P)		kPa	128	148	134	119	104
Available head (2P)		kPa	112	139	124	105	88
Standard pumps, hot circuit (W7; W45°C)							
Pump model			P3	P4	P5	P5	P6
Available head (1R)		kPa	150	151	182	175	198
Available head (2R)		kPa	143	141	169	159	181
Noise levels							
Sound power level of SLN unit	(4)	dB(A)	84	85	86	86	86
Sound pressure level of SLN unit	(5)	dB(A)	52	53	54	54	54
Dimensions and weights of basic unit							
Length		mm	5002	5002	5002	5002	5002
Depth		mm	2256	2256	2256	2256	2256
Height		mm	2443	2443	2443	2443	2443
Operating weight of basic version		kg	3698	4044	4090	4172	4216

(CH): when the unit is working in cooling only mode; (HP): when the unit is working in heating only mode

- (1) External air temperature 35°C, user-side heat exchanger water inlet/outlet temperature 12/7°C. Values in accordance with EN 14511.
- (2) Outside air temperature 7°C and input/output water temperature into/from user-side heat exchanger 40/45°C Values compliant with standard EN 14511
- (3) Cold-side exchanger inlet-outlet water temperature 12-7°C; Hot-side exchanger inlet-outlet water temperature 40-45°C Values compliant with standard EN 14511
- (4) Unit operating at rated capacity, with no accessories of any kind - external air temperature 35°C and water input/output temperature from/to heat exchanger and user equal to 12/7°C. Values taken by measurements made in accordance with standard ISO 3744 and the Eurovent certification programme, where applicable. Binding values See NOISE LEVELS section.
- (5) Values obtained from the sound power level (conditions: note 4), related to a distance of 10 m from the unit in free field with directivity factor Q=2. Non-binding values See NOISE LEVELS section.

OMICRON REV S4 SLN

			51.6	60.6	68.8	75.8	82.8
Cooling (A35°C; W7°C)							
Refrigeration capacity	(1)	kW	500	605	666	726	807
Total absorbed power	(1)	kW	174	230	232	274	306
EER	(1)		2,88	2,63	2,87	2,65	2,64
Heating (A7°C/87%; W45°C)							
Heating capacity	(2)	kW	541	660	722	798	881
Total absorbed power	(2)	kW	173	209	230	255	283
COP	(2)		3,13	3,15	3,14	3,13	3,12
Cooling + Heating (W7°C; W45°C)							
Refrigeration capacity	(3)	kW	479	613	639	723	805
Heating capacity	(3)	kW	633	808	844	957	1070
Total absorbed power	(3)	kW	156	197	208	239	270
EER	(3)		3,06	3,11	3,07	3,03	2,98
COP	(3)		4,05	4,09	4,06	4,01	3,96
TER	(3)		7,11	7,2	7,14	7,03	6,95
Compressors							
Compressors/Circuits		n°/n°	6/3	6/3	8/4	8/4	8/4
Minimum capacity reduction step		%	17%	17%	12%	12%	12%
Refrigerant charge		kg	166	191	238	261	271
Fans							
Quantity		n°	12	12	16	16	16
Total air flow rate (CH)		m3/h	192000	192000	256000	256000	256000
Total air flow rate (HP)		m3/h	240000	240000	320000	320000	320000
Cold-side heat exchanger							
Type			Shell & tube				
Quantity		n°	1	1	1	1	1
Water flow rate (A35°C; W7°C)	(1)	m3/h	86	104,1	114,7	125	138,8
Head loss (A35°C; W7°C)	(1)	kPa	38	36	35	49	33
Hot-side heat exchanger							
Type			Shell & tube				
Quantity		n°	1	1	1	1	1
Water flow rate (A7°C/87%; W45°C)	(2)	m3/h	93	113,4	124,1	137,1	151,5
Head loss (A7°C/87%; W45°C)	(2)	kPa	30	21	25	29	44
Hydraulic modules							
Standard pumps, cold circuit (A35°C; W7°C)							
Pump model			P7	P8	P9	P9	P9
Available head (1P)		kPa	140	156	161	135	133
Available head (2P)		kPa	115	120	150	122	117
Standard pumps, hot circuit (W7; W45°C)							
Pump model			P9	P9	P9	P10	P10
Available head (1R)		kPa	193	179	158	180	167
Available head (2R)		kPa	186	169	146	172	158
Noise levels							
Sound power level of SLN unit	(4)	dB(A)	87	88	89	89	90
Sound pressure level of SLN unit	(5)	dB(A)	55	56	56	56	57
Dimensions and weights of basic unit							
Length		mm	7383	7383	9183	9183	9183
Depth		mm	2256	2256	2256	2256	2256
Height		mm	2443	2443	2443	2443	2443
Operating weight of basic version		kg					

(CH): when the unit is working in cooling only mode; (HP): when the unit is working in heating only mode

- (1) External air temperature 35°C, user-side heat exchanger water inlet/outlet temperature 12/7°C. Values in accordance with EN 14511.
- (2) Outside air temperature 7°C and input/output water temperature into/from user-side heat exchanger 40/45°C Values compliant with standard EN 14511
- (3) Cold-side exchanger inlet-outlet water temperature 12-7°C; Hot-side exchanger inlet-outlet water temperature 40-45°C Values compliant with standard EN 14511
- (4) Unit operating at rated capacity, with no accessories of any kind - external air temperature 35°C and water input/output temperature from/to heat exchanger and user equal to 12/7°C. Values taken by measurements made in accordance with standard ISO 3744 and the Eurovent certification programme, where applicable. Binding values See NOISE LEVELS section.
- (5) Values obtained from the sound power level (conditions: note 4), related to a distance of 10 m from the unit in free field with directivity factor Q=2. Non-binding values See NOISE LEVELS section.

ECODESIGN

INTRODUCTION

The Ecodesign/ErP Directive (2009/125/EC) lays down new standards for more efficient energy use.

The Directive contains various regulations; as regards chiller products and heat pumps, the regulations of interest are the following:

- Regulation 2013/813, for small heat pumps ($P_{\text{design}} \leq 400$ kW)
- Regulation 2016/2281, for chillers and heat pumps with $P_{\text{design}} > 400$ kW
- Regulation 2013/811, for heat pumps with $P_{\text{design}} \leq 70$ kW.

The last-mentioned regulation (2013/811) regards the labelling (Ecolabel certification) of small heat pumps.

The other two regulations (2013/813 and 2016/2281) set seasonal efficiency targets that the products must comply with to be sold and installed in the European Union (essential requirement for CE marking).

These efficiency limits are defined through ratios, which are respectively:

- η_{sh} (SCOP), with reference to regulation 2013/813
- η_{sc} (SEER) for comfort applications and SEPR for process applications, with reference to regulation 2016/2281.

As regards regulation 2016/2281, with effect from 1st January 2021, the required minimum efficiency limit will be raised (Tier 2) from the current threshold (Tier 1).

The figure below schematically illustrates the correspondence between product and reference energy ratio.

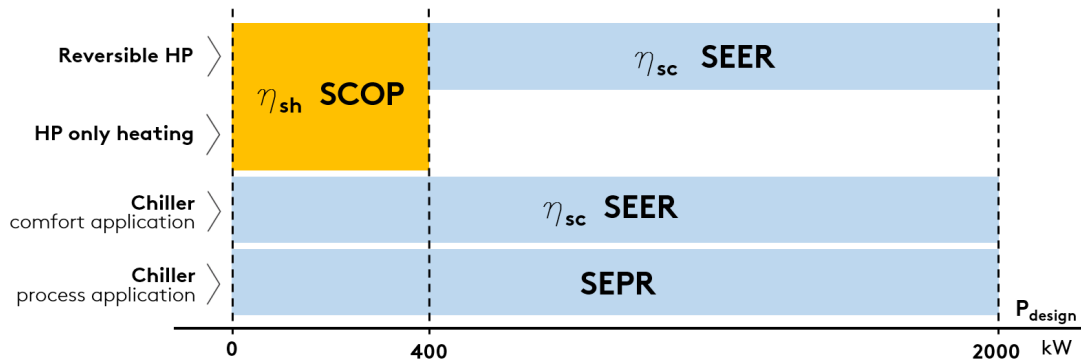

Some notes and clarifications:

For comfort applications, regulation 2016/2281 sets the η_{sc} (SEER) ratio in two different operating conditions:

- SEER calculated with machine inlet/outlet water temperature of 12/7°C (low temperature application),
- SEER calculated with machine inlet/outlet water temperature of 23/18°C (medium temperature application).

The minimum efficiency requirement is the same, but can be met at condition 12/7°C or at condition 23/18°C, depending on the application envisaged for the machine.

Regulation 2013/813 distinguishes two different types: at low temperature and at medium temperature.

The following refer to the application at low temperature: (low temperature application) all heat pumps whose maximum delivery temperature for heating purposes is lower than 52°C with source at temperature of -7°C and -8°C wet bulb (air-water unit) or inlet 10°C (water-water unit), at the reference design conditions for an average climate. For these, the efficiency ratio is "low temperature application" (outlet water temperature 35°C).

For all the other heat pumps, the efficiency ratio is related to "medium temperature application" (outlet water temperature 55°C).

The ratios must be calculated according to the reference European heating season in average climatic conditions.

The minimum efficiency requirements set by the regulations are indicated below.

REGULATION 2016/2281, comfort application

TYPE OF UNIT		MINIMUM REQUIREMENT			
SOURCE	Pdesign	Tier 1		Tier 2 (2021)	
		η_{sc} [%]	SEER	η_{sc} [%]	SEER
air	< 400kW	149	3,8	161	4,1
air	\geq 400kW	161	4,1	179	4,55
water	< 400kW	196	5,1	200	5,2
water	\geq 400kW and < 1500kW	227	5,875	252	6,5
water	\geq 1500kW	245	6,325	272	7

REGULATION 2016/2281, process application

TYPE OF UNIT		MINIMUM REQUIREMENT	
SOURCE	Pdesign	Tier 1	Tier 2 (2021)
		SEPR	SEPR
air	< 400kW	4,5	5
air	\geq 400kW	5	5,5
water	< 400kW	6,5	7
water	\geq 400kW and < 1500kW	7,5	8
water	\geq 1500kW	8	8,5

REGULATION 2013/813

SOURCE	APPLICATION	MINIMUM REQUIREMENT	
		η_{sh} [%]	SCOP
air	low temperature application	125	3,2
water	low temperature application	125	3,325
air	medium temperature application	110	2,825
water	medium temperature application	110	2,95

The conformity of the product must be checked according to the type of application, whether comfort or process, and at the required outlet water temperature.

The two schematic tables below, respectively for comfort application and for process application, indicate the reference of the required conformity according to the type of product and the set point temperature (reference to regulations 2016/2281 and 2013/813).

Important note: for mixed comfort and process applications, the reference application for conformity is the comfort application.

COMFORT APPLICATION

PRODUCT	OUTLET WATER TEMPERATURE	COMPLIANCE INDEX	REGULATION
Chiller	< 18°C	SEER/η _{sc} low temperature application	2016/2281
	≥ 18°C	SEER/η _{sc} medium temperature application	2016/2281
Heat pumps (reversible and only heating) P_{design} ≤ 400kW		SCOP/η _{sh}	2013/813
Reversible heat pumps P_{design} > 400kW	< 18°C	SEER/η _{sc} low temperature application	2016/2281
	≥ 18°C	SEER/η _{sc} medium temperature application	2016/2281
Heat pumps only heating P_{design} > 400kW		-	-

- = exemption from Ecodesign

PROCESS APPLICATION

PRODUCT	OUTLET WATER TEMPERATURE	COMPLIANCE INDEX	REGULATION
Chiller	≥ +2°C , ≤ 12°C	SEPR	2016/2281
	> 12°C	-	-
	> -8°C , < +2°C	-	-

- = exemption from Ecodesign

Some specifications and notes follow.

Partly completed machinery

The term partly completed machinery refers to all units without a user-side or source-side heat exchanger, and therefore to all LC, LE, LC/HP and LE/HP versions. Since these are "non-complete" machines, conformity with Ecodesign depends on combination with the remote heat exchanger.

All the partly completed machinery is CE marked and accompanied by a declaration of conformity. Installation in European Union countries is therefore allowed; correct selection and installation of the remote heat exchanger must be ensured, in accordance with the above cases.

EC fans:

The only option that positively affects the performance of the unit, by increasing its seasonal energy efficiency ratio, is the VEC accessory.

A unit equipped with EC fans has a higher SEER (η_{sc}) than the configuration with standard fans.

OMICRON REV S4 RANGE

The Ecodesign/ErP Directive (2009/125/EC) lays down new standards for more efficient energy use. Several regulations are part of the directive, and set mandatory seasonal efficiency targets for sale in the European Union.

The unit therefore, to be CE marked and sold in the EU market, must comply with the minimum requirements imposed by the regulations in question.

Regarding the OMICRON REV S4 range, the reference regulations in the various configurations are:

- Regulation 2013/813, for heat pump Pdesign \leq 400 kW
- Regulation 2016/2281, for chillers and heat pumps with Pdesign $>$ 400 kW

Minimum efficiency requirements are imposed through seasonal energy efficiency indices, respectively:

- η_{sh} (SCOP), with reference to regulation 2013/813
- η_{sc} (SEER) for comfort applications and SEPR for process applications, with reference to regulation 2016/2281

As regards the 2016/2281 regulation starting from 1 January 2021, the minimum required efficiency limit will be raised (Tier 2) compared to the current standard (Tier 1).

With reference to the OMICRON REV S4 range, below is a list of concerned regulations relating to the different units in their various configurations:

OMICRON Rev S4 HE:

and

OMICRON Rev S4 SLN:

- all versions up to size 60.6 regulation 2013/813, from size 68.8 regulation 2016/2281

The tables below give information on the conformity of the units and the seasonal energy performance ratios with regard to the reference regulation.

OMICRON REV S4 HE

			3.2	4.2	5.2	6.2	7.2
REGULATION 2013/813							
Pdesign	(4)	kW	37	40	50	54	58
COMFORT							
Low temperature application							
η_{sh}	(4)	%	132,8	131,6	133,9	132,6	131,4
SCOP	(4)		3,4	3,37	3,42	3,39	3,36
Conformity with Tier 2	(4)		Y	Y	Y	Y	Y

Y = unit in compliance with Ecodesign at the indicated condition.

(4) User-side heat exchanger water inlet/outlet temperature 30/35, Average climate profile, with reference to regulation 2013/813 and norm EN 14825.

OMICRON REV S4 HE

			8.2	11.2	14.2	16.2
REGULATION 2013/813						
Pdesign	(4)	kW	70	95	116	138
COMFORT						
Low temperature application						
η_{sh}	(4)	%	133,4	131,4	129,8	129
SCOP	(4)		3,41	3,36	3,32	3,3
Conformity with Tier 2	(4)		Y	Y	Y	Y

Y = unit in compliance with Ecodesign at the indicated condition.

(4) User-side heat exchanger water inlet/outlet temperature 30/35, Average climate profile, with reference to regulation 2013/813 and norm EN 14825.

OMICRON REV S4 HE

			10.4	12.4	17.4	19.4	21.4	25.4	29.4
REGULATION 2013/813									
Pdesign	(4)	kW	91	118	163	181	194	238	265
COMFORT									
Low temperature application									
η_{sh}	(4)	%	141,7	141	141,7	141	140,3	142,5	141,8
SCOP	(4)		3,62	3,6	3,62	3,6	3,58	3,64	3,62
Conformity with Tier 2	(4)		Y	Y	Y	Y	Y	Y	Y

Y = unit in compliance with Ecodesign at the indicated condition.

(4) User-side heat exchanger water inlet/outlet temperature 30/35, Average climate profile, with reference to regulation 2013/813 and norm EN 14825.

OMICRON REV S4 HE

			32.4	36.4	40.4	43.4	51.6	60.6
REGULATION 2013/813								
Pdesign	(4)	kW	294	325	364	399	399	399
COMFORT								
Low temperature application								
η_{sh}	(4)	%	143,4	142,5	141,8	141	140,2	141
SCOP	(4)		3,66	3,64	3,62	3,6	3,58	3,6
Conformity with Tier 2	(4)		Y	Y	Y	Y	Y	Y

Y = unit in compliance with Ecodesign at the indicated condition.

(4) User-side heat exchanger water inlet/outlet temperature 30/35, Average climate profile, with reference to regulation 2013/813 and norm EN 14825.

OMICRON REV S4 HE

			68.8	75.8	82.8
REGULATION 2016/2281					
Pdesign	(1)	kW	693	779	856
COMFORT					
Standard units					
η_{sc}	(1)	%	164,2	163,4	162,6
SEER	(1)		4,18	4,16	4,14
Compliance Tier 2 (2021)*	(1)		N	N	N
Standard unit with EC fans and hydraulic circuit with variable flow					
η_{sc}	(1)	%	179	179	179
SEER	(1)		4,55	4,55	4,55
Compliance Tier 2 (2021)	(1)		Y	Y	Y

Y = unit in compliance with Ecodesign at the indicated condition.

N = unit not in compliance with Ecodesign at the given condition: it can be installed only in non-EU countries.

(1) User-side heat exchanger water inlet/outlet temperature 12/7°C (low temperature application), with reference to regulation 2016/2281 and standard EN 14825.

(*) Indication is valid only for unit with basic configuration.

Sizes 68.8-75.8-82.8 are compliant with regulation 2016/2281 TIER2 (2021) including EC fans and variable flow rate control in the unit

OMICRON REV S4 SLN

			3.2	4.2	5.2	6.2	7.2
REGULATION 2013/813							
Pdesign	(4)	kW	37	40	50	54	58
COMFORT							
Low temperature application							
η_{sh}	(4)	%	132,8	131,6	133,9	132,6	131,4
SCOP	(4)		3,4	3,37	3,42	3,39	3,36
Conformity with Tier 2	(4)		Y	Y	Y	Y	Y

Y = unit in compliance with Ecodesign at the indicated condition.

(4) User-side heat exchanger water inlet/outlet temperature 30/35, Average climate profile, with reference to regulation 2013/813 and norm EN 14825.

OMICRON REV S4 SLN

			8.2	11.2	14.2	16.2
REGULATION 2013/813						
Pdesign	(4)	kW	70	95	116	138
COMFORT						
Low temperature application						
η_{sh}	(4)	%	133,4	131,4	129,8	129
SCOP	(4)		3,41	3,36	3,32	3,3
Conformity with Tier 2	(4)		Y	Y	Y	Y

Y = unit in compliance with Ecodesign at the indicated condition.

(4) User-side heat exchanger water inlet/outlet temperature 30/35, Average climate profile, with reference to regulation 2013/813 and norm EN 14825.

OMICRON REV S4 SLN

			10.4	12.4	17.4	19.4	21.4	25.4	29.4
REGULATION 2013/813									
Pdesign	(4)	kW	91	118	163	181	194	238	265
COMFORT									
Low temperature application									
η_{sh}	(4)	%	141,7	141	141,7	141	140,3	142,5	141,8
SCOP	(4)		3,62	3,6	3,62	3,6	3,58	3,64	3,62
Conformity with Tier 2	(4)		Y	Y	Y	Y	Y	Y	Y

Y = unit in compliance with Ecodesign at the indicated condition.

(4) User-side heat exchanger water inlet/outlet temperature 30/35, Average climate profile, with reference to regulation 2013/813 and norm EN 14825.

OMICRON REV S4 SLN

			32.4	36.4	40.4	43.4	51.6	60.6
REGULATION 2013/813								
Pdesign	(4)	kW	294	325	364	399	399	399
COMFORT								
Low temperature application								
η_{sh}	(4)	%	143,4	142,5	141,8	141	140,2	141
SCOP	(4)		3,66	3,64	3,62	3,6	3,58	3,6
Conformity with Tier 2	(4)		Y	Y	Y	Y	Y	Y

Y = unit in compliance with Ecodesign at the indicated condition.

(4) User-side heat exchanger water inlet/outlet temperature 30/35, Average climate profile, with reference to regulation 2013/813 and norm EN 14825.

OMICRON REV S4 SLN

				68.8	75.8	82.8
REGULATION 2016/2281						
Pdesign	(1)	kW		666	726	807
COMFORT						
Standard units						
η_{sc}	(1)	%		163,4	162,2	161,4
SEER	(1)			4,16	4,13	4,11
Compliance Tier 2 (2021)*	(1)			N	N	N
Standard unit with EC fans and hydraulic circuit with variable flow						
η_{sc}	(1)	%		179	179	179
SEER	(1)			4,55	4,55	4,55
Compliance Tier 2 (2021)	(1)			Y	Y	Y

Y = unit in compliance with Ecodesign at the indicated condition.

N = unit not in compliance with Ecodesign at the given condition: it can be installed only in non-EU countries.

(1) User-side heat exchanger water inlet/outlet temperature 12/7°C (low temperature application), with reference to regulation 2016/2281 and standard EN 14825.

(*) Indication is valid only for unit with basic configuration.

Sizes 68.8-75.8-82.8 are compliant with regulation 2016/2281 TIER2 (2021) including EC fans and variable flow rate control in the unit

ELECTRICAL SPECIFICATIONS

OMICRON REV S4 HE - OMICRON REV S4 SLN

			3.2	4.2	5.2	6.2	7.2
General electrical specifications							
Max. absorbed power (FLI)	(1)	kW	18,9	21,6	25,9	28,8	32,2
Max. absorbed current (FLA)	(1)	A	36,1	42,6	52,9	55,3	61,5
Nominal current (Inom)	(2)	A	33	35,4	44,1	44,3	54
cosφ standard unit	(2)		0,84	0,84	0,82	0,84	0,76
Nominal current with power factor correction (Inom)	(2)	A	28,4	30,6	38	39,9	43
cosφ unit with power factor correction	(2)		0,97	0,97	0,96	0,97	0,95
Maximum inrush current (MIC)	(3)	A	123	154	172	152	177
Maximum inrush current with soft-starter (MIC)	(4)	A	83	102	116	105	121
Power supply			400/3~/50 +N				
Power supply for auxiliary circuits			230-24/1~/50				
Suggested line section	(5)	mm ²	5G10 FG16OR16		4x25+1G16 FG16OR16		
Suggested line protection	(6)		NH00gG 50A	NH00gG 63A	NH00gG 80A		
Electrical specifications for fans							
Rated power of standard fan		n° x kW	4 x 0,5	4 x 0,5	6 x 0,5	6 x 0,5	6 x 0,5
Rated current of standard fan		n° x A	4 x 2,1	4 x 2,1	6 x 2,1	6 x 2,1	6 x 2,1
Rated power of EC fan		n° x kW	4 x 0,3	4 x 0,3	6 x 0,3	6 x 0,3	6 x 0,3
Rated current of EC fan		n° x A	4 x 2,2	4 x 2,2	6 x 2,2	6 x 2,2	6 x 2,2
Rated power of oversize EC fans		n° x kW	4 x 0,5	4 x 0,5	6 x 0,5	6 x 0,5	6 x 0,5
Rated current of oversize EC fans		n° x A	4 x 2,2	4 x 2,2	6 x 2,2	6 x 2,2	6 x 2,2

- (1) Data regarding the unit without accessories working in maximum power absorption conditions
- (2) Datum related to the unit without accessories working in standard conditions (A35°C; W12-7°C)
- (3) Maximum effective RMS value of the current when the last compressor starts (FLA of the entire unit - FLA of the largest compressor + LRA of the largest compressor)
- (4) Maximum effective RMS value of the current when the last compressor starts (FLA of the entire unit - FLA of the largest compressor + 0.6 x LRA of the largest compressor)
- (5) These values are determined for cables with operating temperature of 40°C, EPR insulation and a line with a maximum length of 50m. The line section must be determined by a qualified technician based on the protection devices, the length of the line, the type of cable used and the type of installation.
- (6) The correct line protection part must be determined by a qualified technician based on the length of the line, the type of cable used and the type of installation.

OMICRON REV S4 HE - OMICRON REV S4 SLN

			8.2	11.2	14.2	16.2
General electrical specifications						
Max. absorbed power (FLI)	(1)	kW	37,9	46,4	61	80,2
Max. absorbed current (FLA)	(1)	A	71,8	79	105	135,8
Nominal current (Inom)	(2)	A	59	61,8	79	95
cosφ standard unit	(2)		0,76	0,79	0,84	0,84
Nominal current with power factor correction (Inom)	(2)	A	46	50	70	83
cosφ unit with power factor correction	(2)		0,98	0,98	0,95	0,96
Maximum inrush current (MIC)	(3)	A	214	285	349	387
Maximum inrush current with soft-starter (MIC)	(4)	A	145	188	234	263
Power supply			400/3~/50			
Power supply for auxiliary circuits			230-24/1~/50			
Suggested line section	(5)	mm ²	3x35+1G25 FG16OR16		3x70+1G35 FG16OR16	
Suggested line protection	(6)		NH00gG 100A		NH00gG 160A	
Electrical specifications for fans						
Rated power of standard fan		n° x kW	2 x 2,0	2 x 2,0	4 x 2,0	4 x 2,0
Rated current of standard fan		n° x A	2 x 4,3	2 x 4,3	4 x 4,3	4 x 4,3
Rated power of EC fan		n° x kW	2 x 1,9	2 x 1,9	4 x 1,9	4 x 1,9
Rated current of EC fan		n° x A	2 x 2,9	2 x 2,9	4 x 2,9	4 x 2,9
Rated power of oversize EC fans		n° x kW	2 x 3,0	2 x 3,0	4 x 3,0	4 x 3,0
Rated current of oversize EC fans		n° x A	2 x 4,5	2 x 4,5	4 x 4,5	4 x 4,5

- (1) Data regarding the unit without accessories working in maximum power absorption conditions
- (2) Datum related to the unit without accessories working in standard conditions (A35°C; W12-7°C)
- (3) Maximum effective RMS value of the current when the last compressor starts (FLA of the entire unit - FLA of the largest compressor + LRA of the largest compressor)
- (4) Maximum effective RMS value of the current when the last compressor starts (FLA of the entire unit - FLA of the largest compressor + 0.6 x LRA of the largest compressor)
- (5) These values are determined for cables with operating temperature of 40°C, EPR insulation and a line with a maximum length of 50m. The line section must be determined by a qualified technician based on the protection devices, the length of the line, the type of cable used and the type of installation.
- (6) The correct line protection part must be determined by a qualified technician based on the length of the line, the type of cable used and the type of installation.

OMICRON REV S4 HE - OMICRON REV S4 SLN

			10.4	12.4	17.4	19.4	21.4	25.4
General electrical specifications								
Max. absorbed power (FLI)	(1)	kW	45	50	76	87	98	107
Max. absorbed current (FLA)	(1)	A	75	86	144	153	163	184
Nominal current (Inom)	(2)	A	66	75	118	127	136	147
cosφ standard unit	(2)		0,79	0,79	0,76	0,8	0,83	0,83
Nominal current with power factor correction (Inom)	(2)	A	53	62	92	107	118	129
cosφ unit with power factor correction	(2)		0,98	0,96	0,98	0,95	0,96	0,95
Maximum inrush current (MIC)	(3)	A	169	184	286	342	352	428
Maximum inrush current with soft-starter (MIC)	(4)	A	125	137	216	252	262	313
Power supply			400/3~/50					
Power supply for auxiliary circuits			230-24/1~/50					
Suggested line section	(5)	mm²	3x25+1G16 FG16OR16	3x35+1G25 FG16OR16	3x50+1G25 FG16OR16	3x70+1G35 FG16OR16		3x120+1G70 FG16OR16
Suggested line protection	(6)		NH00gG 100A	NH00gG 125A	NH00gG 160A	NH1gG 200A		NH1gG 250A
Electrical specifications for fans								
Rated power of standard fan		n° x kW	2 x 2,0	2 x 2,0	4 x 2,0	4 x 2,0	4 x 2,0	6 x 2,0
Rated current of standard fan		n° x A	2 x 4,3	2 x 4,3	4 x 4,3	4 x 4,3	4 x 4,3	6 x 4,3
Rated power of EC fan		n° x kW	2 x 1,9	2 x 1,9	4 x 1,9	4 x 1,9	4 x 1,9	6 x 1,9
Rated current of EC fan		n° x A	2 x 2,9	2 x 2,9	4 x 2,9	4 x 2,9	4 x 2,9	6 x 2,9
Rated power of oversize EC fans		n° x kW	2 x 3,0	2 x 3,0	4 x 3,0	4 x 3,0	4 x 3,0	6 x 3,0
Rated current of oversize EC fans		n° x A	2 x 4,5	2 x 4,5	4 x 4,5	4 x 4,5	4 x 4,5	6 x 4,5

			29.4	32.4	36.4	40.4	43.4	
General electrical specifications								
Max. absorbed power (FLI)	(1)	kW	118	141	160	178	196	
Max. absorbed current (FLA)	(1)	A	201	241	272	301	330	
Nominal current (Inom)	(2)	A	151	175	191	230	270	
cosφ standard unit	(2)		0,84	0,84	0,84	0,84	0,85	
Nominal current with power factor correction (Inom)	(2)	A	133	153	166	205	239	
cosφ unit with power factor correction	(2)		0,96	0,96	0,96	0,95	0,95	
Maximum inrush current (MIC)	(3)	A	445	492	522	635	664	
Maximum inrush current with soft-starter (MIC)	(4)	A	330	368	398	472	501	
Power supply			400/3~/50					
Power supply for auxiliary circuits			230-24/1~/50					
Suggested line section	(5)	mm²	3x120+1G70 FG16OR16	3x150+1G95 FG16OR16			2x(3x70) +1G95 FG16OR16	
Suggested line protection	(6)		NH1gG 250A	NH2gG 315A			NH2gG 400A	
Electrical specifications for fans								
Rated power of standard fan		n° x kW	6 x 2,0	8 x 2,0	8 x 2,0	8 x 2,0	8 x 2,0	
Rated current of standard fan		n° x A	6 x 4,3	8 x 4,3	8 x 4,3	8 x 4,3	8 x 4,3	
Rated power of EC fan		n° x kW	6 x 1,9	8 x 1,9	8 x 1,9	8 x 1,9	8 x 1,9	
Rated current of EC fan		n° x A	6 x 2,9	8 x 2,9	8 x 2,9	8 x 2,9	8 x 2,9	
Rated power of oversize EC fans		n° x kW	6 x 3,0	8 x 3,0	8 x 3,0	8 x 3,0	8 x 3,0	
Rated current of oversize EC fans		n° x A	6 x 4,5	8 x 4,5	8 x 4,5	8 x 4,5	8 x 4,5	

- (1) Data regarding the unit without accessories working in maximum power absorption conditions
- (2) Datum related to the unit without accessories working in standard conditions (A35°C; W12-7°C)
- (3) Maximum effective RMS value of the current when the last compressor starts (FLA of the entire unit - FLA of the largest compressor + LRA of the largest compressor)
- (4) Maximum effective RMS value of the current when the last compressor starts (FLA of the entire unit - FLA of the largest compressor + 0.6 x LRA of the largest compressor)
- (5) These values are determined for cables with operating temperature of 40°C, EPR insulation and a line with a maximum length of 50m. The line section must be determined by a qualified technician based on the protection devices, the length of the line, the type of cable used and the type of installation.
- (6) The correct line protection part must be determined by a qualified technician based on the length of the line, the type of cable used and the type of installation.

OMICRON REV S4 HE - OMICRON REV S4 SLN

			51.6	60.6	68.8	75.8	82.8
General electrical specifications							
Max. absorbed power (FLI)	(1)	kW	241	294	321	356	392
Max. absorbed current (FLA)	(1)	A	407	494	543	601	659
Nominal current (Inom)	(2)	A	286	405	381	461	540
cosφ standard unit	(2)		0,84	0,85	0,84	0,84	0,85
Nominal current with power factor correction (Inom)	(2)	A	249	359	333	402	479
cosφ unit with power factor correction	(2)		0,96	0,95	0,96	0,97	0,95
Maximum inrush current (MIC)	(3)	A	658	829	794	935	993
Maximum inrush current with soft-starter (MIC)	(4)	A	534	665	670	772	830
Power supply			400/3~/50				
Power supply for auxiliary circuits			230-24/1~/50				
Suggested line section	(5)	mm²	2x(3x120) +1G120 FG16OR16	2x(3x185) +1G185 FG16OR16		3x(3x185) +2G120 FG16OR16	3x(3x185) +2G120 FG16OR16
Suggested line protection	(6)		NH3gG 500A	NH3gG 630A		NH3gG 800A	
Electrical specifications for fans							
Rated power of standard fan		n° x kW	12 x 2,0	12 x 2,0	16 x 2,0	16 x 2,0	16 x 2,0
Rated current of standard fan		n° x A	12 x 4,3	12 x 4,3	16 x 4,3	16 x 4,3	16 x 4,3
Rated power of EC fan		n° x kW	12 x 1,9	12 x 1,9	16 x 1,9	16 x 1,9	16 x 1,9
Rated current of EC fan		n° x A	12 x 2,9	12 x 2,9	16 x 2,9	16 x 2,9	16 x 2,9
Rated power of oversize EC fans		n° x kW	12 x 3,0	12 x 3,0	16 x 3,0	16 x 3,0	16 x 3,0
Rated current of oversize EC fans		n° x A	12 x 4,5	12 x 4,5	16 x 4,5	16 x 4,5	16 x 4,5

- (1) Data regarding the unit without accessories working in maximum power absorption conditions
- (2) Datum related to the unit without accessories working in standard conditions (A35°C; W12-7°C)
- (3) Maximum effective RMS value of the current when the last compressor starts (FLA of the entire unit - FLA of the largest compressor + LRA of the largest compressor)
- (4) Maximum effective RMS value of the current when the last compressor starts (FLA of the entire unit - FLA of the largest compressor + 0.6 x LRA of the largest compressor)
- (5) These values are determined for cables with operating temperature of 40°C, EPR insulation and a line with a maximum length of 50m. The line section must be determined by a qualified technician based on the protection devices, the length of the line, the type of cable used and the type of installation.
- (6) The correct line protection part must be determined by a qualified technician based on the length of the line, the type of cable used and the type of installation.

HYDRAULIC MODULES

Model	Rated power	Rated current	Qmin	Qmax
	kW	A	m³/h	m³/h
P1	1,5	3,2	12	42
P2	2,2	4,5	12	42
P3	3	6,1	24	72
P4	4	8,7	38	110
P5	5,5	10,4	42	126
P6	7,5	13,6	42	132
P7	7,5	13,6	42	126
P8	9,2	17,2	42	132
P9	11	20,2	58	237
P10	15	27,1	50	240
P11	0,6	1,6	4	10
P12	0,9	2,1	4	10
P13	0,8	1,9	7	18
P14	1,1	2,5	7	18
P16	1,1	2,4	12	26
P17	1,5	3,4	12	29

USER-SIDE EXCHANGER FLOW RATE FIELDS

The units are sized and optimized for the following nominal conditions: external air 35°C, inlet-outlet of the user-side exchanger 12/7°C.

The units can work at design conditions different from nominal conditions, provided that:

- the design condition falls within the operating limits specified below
- the unit is equipped with all the accessories necessary for operation (e.g. brine kit, fan speed adjuster, HAT)
- the flow rate at design conditions (that is, of the specific application) must always come within the allowed flow rate ranges specified below. If the design conditions require a water flow rate that does not come within the allowed operating range, you must contact our sales department that will identify the most suitable solution for the specific application.

OMICRON REV S4 HE

	Cold-side heat exchanger		Hot-side heat exchanger	
	Qmin	Qmax	Qmin	Qmax
	m ³ /h	m ³ /h	m ³ /h	m ³ /h
3.2	3,6	10,7	3,7	11
4.2	4,1	12,4	4,1	12,4
5.2	4,9	14,7	5	15,1
6.2	5,4	16,1	5,5	16,5
7.2	6,1	18,2	6	18
8.2	7,2	21,6	7,2	21,7
11.2	9	26,9	8,7	26,2
14.2	11,6	34,9	11,7	35,2
16.2	14,5	43,5	14,6	43,8
10.4	8,4	25,2	8,6	25,7
12.4	9,4	28,3	9,8	29,5
17.4	14,7	44,1	15,3	46
19.4	16,6	49,9	16,9	50,8
21.4	18,3	54,9	18,6	55,9
25.4	21,5	64,4	22,3	66,8
29.4	23,5	70,5	24,6	73,7
32.4	27,5	82,5	27,7	83,2
36.4	30,6	91,8	30,9	92,7
40.4	34,6	103,9	34,4	103,1
43.4	37,8	113,4	37,4	112,2
51.6	45	134,9	46,5	139,5
60.6	55,2	165,7	56,7	170,1
68.8	59,7	179	62	186,1
75.8	67	201,1	68,6	205,7
82.8	73,7	221	75,7	227,2

USER-SIDE EXCHANGER FLOW RATE FIELDS

The units are sized and optimized for the following nominal conditions: external air 35°C, inlet-outlet of the user-side exchanger 12/7°C.

The units can work at design conditions different from nominal conditions, provided that:

- the design condition falls within the operating limits specified below
- the unit is equipped with all the accessories necessary for operation (e.g. brine kit, fan speed adjuster, HAT)
- the flow rate at design conditions (that is, of the specific application) must always come within the allowed flow rate ranges specified below. If the design conditions require a water flow rate that does not come within the allowed operating range, you must contact our sales department that will identify the most suitable solution for the specific application.

OMICRON REV S4 SLN

	Cold-side heat exchanger		Hot-side heat exchanger	
	Qmin	Qmax	Qmin	Qmax
	m ³ /h	m ³ /h	m ³ /h	m ³ /h
3.2	3,4	10,3	3,7	11
4.2	3,9	11,8	4,1	12,4
5.2	4,6	13,8	5	15,1
6.2	5,1	15,4	5,5	16,5
7.2	5,8	17,3	6	18
8.2	6,8	20,3	7,3	21,9
11.2	8,5	25,4	8,8	26,5
14.2	11	33,1	11,7	35,2
16.2	13,6	40,9	14,6	43,8
10.4	8	24	8,6	25,7
12.4	8,9	26,6	9,8	29,5
17.4	14,2	42,6	15,3	46
19.4	15,9	47,6	16,9	50,8
21.4	17,3	51,8	18,6	55,9
25.4	20,8	62,3	22,3	66,8
29.4	22,8	68,4	24,6	73,7
32.4	26,5	79,6	27,7	83,2
36.4	29,3	88	30,9	92,7
40.4	33,1	99,4	34,4	103,1
43.4	35,7	107,2	37,4	112,2
51.6	43	129,1	46,5	139,5
60.6	52,1	156,2	56,7	170,1
68.8	57,4	172,1	62	186,1
75.8	62,5	187,6	68,6	205,7
82.8	69,4	208,2	75,7	227,2

OPERATING LIMITS

HEATING

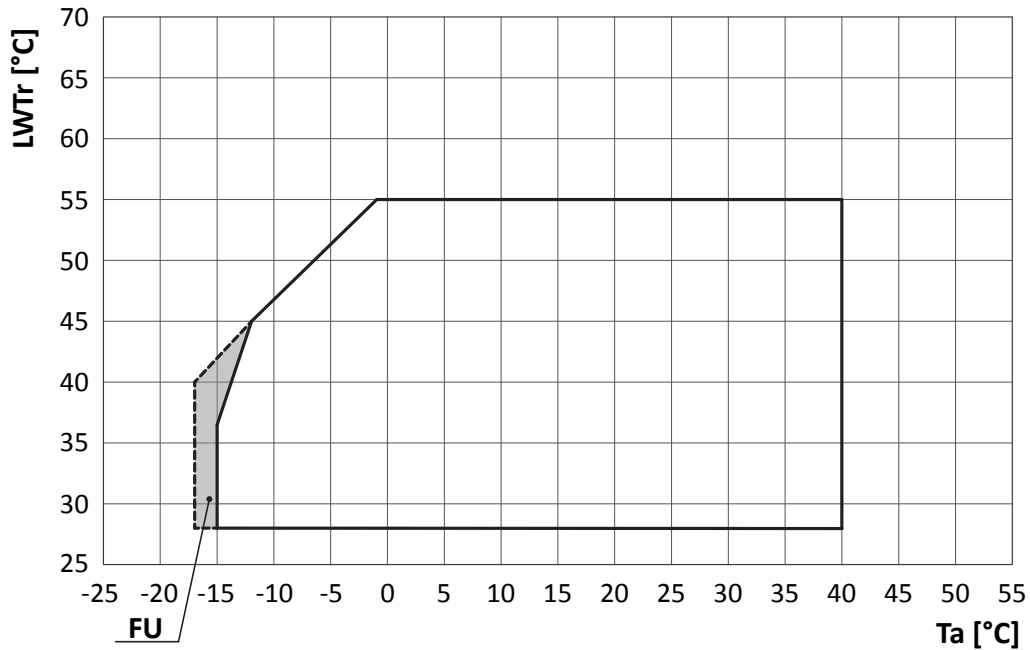

COOLING

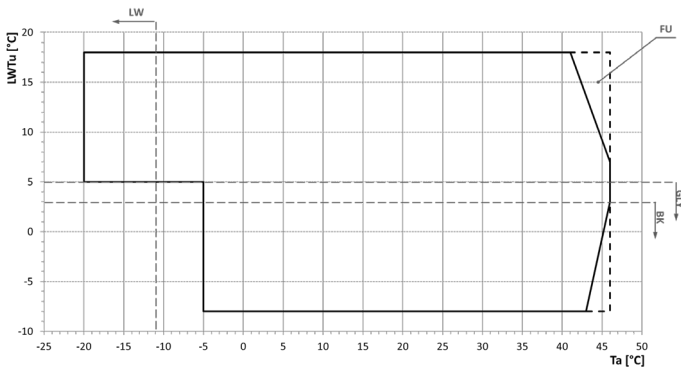

COOLING+HEATING

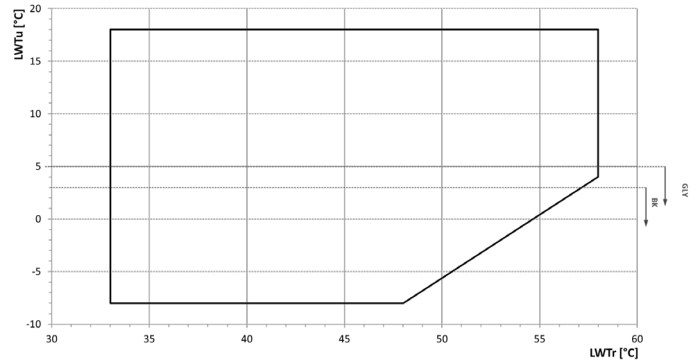

- Ta:** external air temperature
- LWTu:** water outlet temperature from the cold-side exchanger
- LWTr:** water outlet temperature from the hot-side exchanger
- LW:** in the indicated area, the unit can work only where there is no wind
- FU:** in the indicated area, the control could actuate a forced capacity reduction of the compressors so as to prevent tripping of the safety devices
Working envelope not available for 2 compressors units
- BK:** For LWTu below +3°C, it is mandatory to fit the "Brine Kit" accessory

For LWTu below +5°C, it is compulsory to use suitable percentages of antifreeze additives (glycols) to prevent ice formation in the exchanger.

The inlet and outlet temperatures of the user-side exchanger must be given on ordering to allow correct setting of the alarm parameters and verification of the sizing of the expansion valve.

The cooling set point can then be changed by the customer in an interval that, compared to the set point given on ordering, ranges from -1K up to the maximum temperature allowed by the above-stated operating limits.

The unit will be optimized to work at the set point temperatures given on ordering. For different set points, the cooling capacity provided and the level of efficiency of the machine could decrease and move away from these conditions.

NOISE LEVELS

OMICRON REV S4 HE

	Octave bands [dB]																Total [dB(A)]	
	63 Hz		125 Hz		250 Hz		500 Hz		1000 Hz		2000 Hz		4000 Hz		8000 Hz		Lw	Lp
	Lw	Lp	Lw	Lp	Lw	Lp	Lw	Lp	Lw	Lp	Lw	Lp	Lw	Lp	Lw	Lp		
3.2	67	35	74	42	73	41	79	47	82	50	81	49	77	45	72	40	86	54
4.2	66	34	74	42	74	42	79	47	82	50	80	48	77	45	72	40	86	54
5.2	70	38	78	46	78	46	83	51	85	53	84	52	80	48	75	43	90	58
6.2	69	37	76	44	75	43	81	49	84	52	83	51	78	46	74	42	88	56
7.2	70	38	76	44	75	43	81	49	83	51	83	51	78	46	74	42	88	56
8.2	93	61	82	50	80	48	84	52	84	52	84	52	79	47	74	42	89	57
11.2	90	58	80	48	80	48	81	49	83	51	87	55	79	47	71	39	90	58
14.2	93	61	82	50	83	51	83	51	83	51	88	56	80	48	73	41	91	59
16.2	91	59	81	49	82	50	84	52	87	55	86	54	80	48	73	41	91	59
10.4	89	57	78	46	77	45	81	49	79	47	79	47	76	44	71	39	85	53
12.4	89	57	78	46	77	45	81	49	80	48	79	47	75	43	70	38	85	53
17.4	90	58	79	47	78	46	80	48	81	49	81	49	76	44	72	40	86	54
19.4	89	57	79	47	80	48	82	50	81	49	84	52	77	45	71	39	88	56
21.4	89	57	79	47	81	49	82	50	82	50	85	53	78	46	69	37	89	57
25.4	92	59	82	49	82	49	85	53	86	53	84	52	78	46	73	41	90	58
29.4	93	60	83	50	82	50	86	53	86	54	86	53	79	47	74	42	91	59
32.4	94	61	84	51	83	51	88	55	87	55	86	54	81	48	78	45	92	60
36.4	94	62	84	52	84	51	89	57	88	56	87	54	82	49	80	48	93	61
40.4	94	62	84	52	86	54	89	56	88	55	85	53	80	48	87	55	93	61
43.4	93	60	83	50	87	54	90	57	90	57	85	52	80	48	77	44	93	61
51.6	95	63	85	53	85	52	90	58	89	57	88	55	83	50	81	49	94	62
60.6	95	62	85	52	89	56	92	59	92	59	87	54	82	50	78	46	95	63
68.8	97	64	87	54	87	54	92	59	91	58	90	57	85	52	83	50	96	63
75.8	97	64	87	54	89	56	92	59	91	58	88	55	83	50	90	57	96	63
82.8	97	64	87	54	90	57	94	61	94	61	89	56	84	51	80	47	97	64

Reference conditions: External air temperature 35°C; user-side heat exchanger water water inlet-outlet temperature of 12-7°C; unit operating at nominal operating capacity, without any accessories.

Lw: sound power levels.

Lw_tot is the only binding value.

Values obtained from measures taken according to standard ISO 3744.

Lp: sound pressure levels calculated from sound power levels, related to distance of 10 m from the unit in free field with directivity factor Q=2. Non-binding values.

The acoustic data are related to standard conditions in referable and reproducible operating conditions. All data with the exception of Lw_tot are provided for illustrative purposes only and can not be used for forecasting purposes or for the verification of binding limits.

With special reference to noise emissions, the Manufacturer takes liability for their conformity, limited to the declared Lw_tot value. Any and all other Manufacturer's liability for the impact of such emissions in relation to the location of the machine and other conditions related to machine installation is excluded. The environment and the installation conditions, as well as the operating modes, can alter the sound emissions. Any assessment concerning these conditions falls within the area of competence of the plant designer and/or the fitter.

OMICRON REV S4 HE LN

	Octave bands [dB]																Total [dB(A)]	
	63 Hz		125 Hz		250 Hz		500 Hz		1000 Hz		2000 Hz		4000 Hz		8000 Hz		Lw	Lp
	Lw	Lp	Lw	Lp	Lw	Lp	Lw	Lp	Lw	Lp	Lw	Lp	Lw	Lp	Lw	Lp		
3.2	65	33	72	40	71	39	77	45	79	47	78	46	75	43	70	38	84	52
4.2	64	32	72	40	72	40	77	45	79	47	78	46	75	43	70	38	84	52
5.2	68	36	76	44	76	44	81	49	83	51	82	50	78	46	74	42	88	56
6.2	67	35	74	42	73	41	79	47	81	49	81	49	76	44	72	40	86	54
7.2	69	37	74	42	73	41	79	47	81	49	81	49	77	45	72	40	86	54
8.2	91	59	80	48	78	46	82	50	82	50	82	50	77	45	72	40	87	55
11.2	88	56	78	46	78	46	79	47	81	49	85	53	77	45	70	38	88	56
14.2	91	59	80	48	81	49	81	49	81	49	86	54	78	46	71	39	89	57
16.2	89	57	79	47	80	48	82	50	85	53	84	52	78	46	71	39	89	57
10.4	84	52	74	42	73	41	77	45	75	43	75	43	72	40	67	35	81	49
12.4	84	52	74	42	73	41	77	45	76	44	75	43	71	39	67	35	81	49
17.4	85	53	75	43	74	42	76	44	77	45	77	45	73	41	68	36	82	50
19.4	85	53	75	43	76	44	78	46	78	46	80	48	73	41	67	35	84	52
21.4	85	53	75	43	78	46	78	46	78	46	81	49	74	42	66	34	85	53
25.4	87	55	78	45	78	46	81	49	82	49	80	48	75	42	70	37	86	54
29.4	88	56	79	46	79	46	82	49	82	50	82	49	76	43	71	38	87	55
32.4	89	57	80	47	79	47	84	51	83	51	82	50	77	44	74	42	88	56
36.4	90	57	80	48	80	47	85	53	84	52	83	50	78	46	76	44	89	57
40.4	90	57	80	48	82	50	85	52	84	51	81	49	77	44	83	51	89	57
43.4	89	56	79	47	83	50	86	53	86	53	81	48	77	44	73	40	89	57
51.6	91	58	81	49	81	48	86	53	85	53	84	51	79	47	77	45	90	58
60.6	91	58	81	49	85	52	88	55	88	55	83	50	79	46	75	43	91	59
68.8	93	60	83	50	83	50	88	55	87	54	86	53	81	48	79	46	92	59
75.8	93	60	84	51	85	52	88	55	87	54	84	51	80	47	86	53	92	59
82.8	93	60	83	50	87	54	90	57	90	57	85	52	81	48	77	44	93	60

Reference conditions: External air temperature 35°C; user-side heat exchanger water inlet-outlet temperature of 12-7°C; unit operating at nominal operating capacity, without any accessories.

Lw: sound power levels.

Lw_tot is the only binding value.

Values obtained from measures taken according to standard ISO 3744.

Lp: sound pressure levels calculated from sound power levels, related to distance of 10 m from the unit in free field with directivity factor Q=2. Non-binding values.

The acoustic data are related to standard conditions in referable and reproducible operating conditions. All data with the exception of Lw_tot are provided for illustrative purposes only and can not be used for forecasting purposes or for the verification of binding limits.

With special reference to noise emissions, the Manufacturer takes liability for their conformity, limited to the declared Lw_tot value.

Any and all other Manufacturer's liability for the impact of such emissions in relation to the location of the machine and other conditions related to machine installation is excluded. The environment and the installation conditions, as well as the operating modes, can alter the sound emissions. Any assessment concerning these conditions falls within the area of competence of the plant designer and/or the fitter.

OMICRON REV S4 SLN

	Octave bands [dB]																Total [dB(A)]	
	63 Hz		125 Hz		250 Hz		500 Hz		1000 Hz		2000 Hz		4000 Hz		8000 Hz			
	Lw	Lp	Lw	Lp	Lw	Lp	Lw	Lp	Lw	Lp	Lw	Lp	Lw	Lp	Lw	Lp	Lw	Lp
3.2	63	31	69	37	69	37	74	42	76	44	75	43	72	40	67	35	81	49
4.2	61	29	69	37	70	38	74	42	76	44	75	43	72	40	68	36	81	49
5.2	66	34	73	41	73	41	78	46	80	48	79	47	75	43	71	39	85	53
6.2	64	32	71	39	70	38	76	44	78	46	78	46	74	42	69	37	83	51
7.2	66	34	71	39	70	38	76	44	78	46	78	46	74	42	69	37	83	51
8.2	88	56	77	45	75	43	79	47	79	47	79	47	74	42	70	38	84	52
11.2	85	53	75	43	75	43	76	44	78	46	82	50	74	42	67	35	85	53
14.2	87	55	77	45	79	47	78	46	78	46	83	51	76	44	69	37	86	54
16.2	86	54	76	44	77	45	79	47	81	49	81	49	75	43	69	37	86	54
10.4	81	49	71	39	70	38	73	41	72	40	72	40	69	37	64	32	78	46
12.4	81	49	71	39	70	38	74	42	73	41	72	40	69	37	64	32	78	46
17.4	82	50	72	40	71	39	73	41	74	42	74	42	70	38	65	33	79	47
19.4	82	50	73	41	73	41	75	43	75	43	77	45	71	39	65	33	81	49
21.4	82	50	72	40	75	43	76	44	75	43	78	46	71	39	64	32	82	50
25.4	91	58	81	48	79	46	80	47	78	45	76	43	72	40	69	36	83	51
29.4	92	60	82	49	80	47	81	48	79	46	77	44	73	41	70	37	84	52
32.4	88	55	78	46	77	45	81	49	80	48	79	46	74	42	72	40	85	53
36.4	87	54	77	45	77	44	82	49	81	49	80	47	75	43	74	41	86	54
40.4	86	54	78	45	79	47	82	49	81	48	78	46	74	41	80	48	86	54
43.4	85	53	76	44	80	47	83	50	82	50	78	46	74	41	70	38	86	54
51.6	84	52	75	43	76	44	83	50	82	50	81	48	76	44	75	42	87	55
60.6	83	51	75	42	81	49	85	52	85	52	80	47	76	43	72	39	88	56
68.8	86	53	77	44	78	45	85	52	84	51	83	50	78	45	77	44	89	56
75.8	86	53	78	45	82	49	85	52	84	51	81	48	76	43	84	51	89	56
82.8	85	52	77	44	83	50	87	54	87	54	82	49	77	44	74	41	90	57

Reference conditions: External air temperature 35°C; user-side heat exchanger water inlet-outlet temperature of 12-7°C; unit operating at nominal operating capacity, without any accessories.

Lw: sound power levels.

Lw_tot is the only binding value.

Values obtained from measures taken according to standard ISO 3744.

Lp: sound pressure levels calculated from sound power levels, related to distance of 10 m from the unit in free field with directivity factor Q=2. Non-binding values.

The acoustic data are related to standard conditions in referable and reproducible operating conditions. All data with the exception of Lw_tot are provided for illustrative purposes only and can not be used for forecasting purposes or for the verification of binding limits.

With special reference to noise emissions, the Manufacturer takes liability for their conformity, limited to the declared Lw_tot value. Any and all other Manufacturer's liability for the impact of such emissions in relation to the location of the machine and other conditions related to machine installation is excluded. The environment and the installation conditions, as well as the operating modes, can alter the sound emissions. Any assessment concerning these conditions falls within the area of competence of the plant designer and/or the fitter.

INSTALLATION ADVICE

The units described in this document are, by nature, strongly affected by the characteristics of the system, the working conditions and the installation site.

Remember that the unit must be installed by a qualified and skilled technician, and in compliance with the national legislation in force in the destination country.

The installation must be done in such a way that it will be possible to carry out all routine and non-routine maintenance operations.

Before starting any work, you must carefully read the "Installation, operation and maintenance manual" of the machine and do the necessary safety checks to prevent any malfunctioning or hazards.

We give some advice below that will allow you to increase the efficiency and reliability of the unit and therefore of the system into which it is inserted.

Water characteristics

To preserve the life of the exchangers, the water is required to comply with some quality parameters and it is therefore necessary to make sure its values fall within the ranges indicated in the following table:

Total hardness	2,0 ÷ 6,0 °f
Langelier index	- 0,4 ÷ 0,4
pH	7,5 ÷ 8,5
Electrical conductivity	10 ÷ 500 µS/cm
Organic elements	-
Hydrogen carbonate (HCO₃⁻)	70 ÷ 300 ppm
Sulphates (SO₄²⁻)	< 50 ppm
Hydrogen carbonate / Sulphates (HCO₃⁻/SO₄²⁻)	> 1
Chlorides (Cl⁻)	< 50 ppm
Nitrates (NO₃⁻)	< 50 ppm
Hydrogen sulphide (H₂S)	< 0,05 ppm
Ammonia (NH₃)	< 0,05 ppm
Sulphites (SO₃), free chlorine (Cl₂)	< 1 ppm
Carbon dioxide (CO₂)	< 5 ppm
Metal cations	< 0,2 ppm
Manganese ions (Mn⁺⁺)	< 0,2 ppm
Iron ions (Fe²⁺ , Fe³⁺)	< 0,2 ppm
Iron + Manganese	< 0,4 ppm
Phosphates (PO₄³⁻)	< 2 ppm
Oxygen	< 0,1 ppm

Installation of water filters on all the hydraulic circuits is obligatory.

The supply of the most suitable filters for the unit can be requested as accessory. In this case, the filters are supplied loose and must be installed by the customer following the instructions given in the installation, operation and maintenance manual.

Glycol mixtures

With temperatures below 5°C, it is mandatory to work with water and anti-freeze mixtures, and also change the safety devices (anti-freeze, etc.), which must be carried out by qualified authorised personnel or by the manufacturer.

Liquid outlet temperature or minimum ambient temperature	°C	0	-5	-10	-15	-20	-25	-30	-35	-40
Freezing point	°C	-5	-10	-15	-20	-25	-30	-35	-40	-45
Ethylene glycol	%	6	22	30	36	41	46	50	53	56
Propylene glycol	%	15	25	33	39	44	48	51	54	57

The quantity of antifreeze should be considered as % on weight

Minimum water content in the system

For correct operation of the unit, it is necessary to ensure a buffering on the system such as to comply with the minimum operating time considering the greater between the minimum OFF time and the minimum ON time. In short, these contribute to limiting the number of times the compressors are switched on per hour and to preventing undesired deviations from the set point of the delivered water temperature.

Larger amounts of water are in any case always preferable, because they allow a smaller number of starts and switch-offs of the compressors, less wear of them and an increase in the efficiency of the system as a consequence of a reduction in the number of transients.

It should also be pointed out that, for air-water units working in heat pump mode, the minimum amount of water must consider the need of the unit to carry out defrosting. Having an adequate buffering volume will allow prevention of too high drifts of the delivered water temperature at the end of the defrost cycle.

The following experimental formula allows to calculate the minimum water volume of the plant.

Formula refers to unit operation in cooling mode and is also valid for heating mode if defrosting cycles are not taken in account.

$$V_{min} = \frac{P_{tot} \cdot 1.000}{N} \cdot \frac{300}{\Delta T \cdot \rho \cdot c_p} + P_{tot} \cdot 0,25$$

where

V_{min} is the minimum water content of the system [l]

P_{tot} is the total cooling capacity of the machine [kW]

N: number of capacity reduction steps

ΔT : differential allowed on the water temperature. Unless otherwise specified, this value is considered to be 2.5K

ρ : density of the heat-carrying fluid. Unless otherwise specified, the density of water is considered

c_p : specific heat of the heat-carrying fluid. Unless otherwise specified, the specific heat of water is considered

Considering the use of water and grouping together some terms, the formula can be re-written as follows:

$$V_{min} = \frac{P_{tot}}{N} \cdot 17,2 + P_{tot} \cdot 0,25$$

N is equal to the number of compressors installed in the unit.

In case of installation in cold climates where the unit has to perform defrosting cycles, it is suggested to use higher water content than that calculated with previous formula; due to very high volumes needed to completely compensate the negative effect of defrost on produced water temperature, are usually accepted higher temperature deviations than typical values accepted for cooling-only unit.

Water content necessary to balance defrost cycle effect on produced water temperatures, depends on various factors:

- type of system
- compressors and circuits number
- maximum temporary acceptable temperature difference from set-point
- Quantity of defrost cycles necessary to proper functioning of the unit (depending on external and working conditions)
- compressors and circuits number

For OMICRON REV S4 units as general, indicative and not binding value, can be considered 3-5 times minimum water content necessary for cooling-only units.

Installation site

To determine the best installation site for the unit and its orientation, you should pay attention to the following points:

- compliance with the clearance spaces indicated in the official dimensional drawing of the unit must be guaranteed so as to ensure accessibility for routine and non-routine maintenance operations
- you should consider the origin of the hydraulic pipes and their diameters because these affect the radiuses of curvature and therefore the spaces needed for installing them
- you should consider the position of the cable inlet on the electrical control panel of the unit as regards the origin of the power supply
- if the installation includes several units side by side, you should consider the position and dimensions of the manifolds of the user-side exchangers and of any recovery exchangers
- if the installation includes several units side by side, you should consider that the minimum distance between units is 3 metres
- you should avoid all obstructions that can limit air circulation to the source-side exchanger or that can cause recirculation between air supply and intake
- you should consider the orientation of the unit to limit, as far as possible, exposure of the source-side exchanger to solar radiation
- if the installation area is particularly windy, the orientation and positioning of the unit must be such as to avoid air recirculation on the coils. If necessary, we advise making windbreak barriers in order to prevent malfunctioning.

Once the best position for the unit has been identified, you must check that the support slab has the following characteristics:

- its dimensions must be proportionate to those of the unit: if possible, longer and wider than the unit by at least 30 cm and 15/20cm higher than the surrounding surface
- it must be able to bear at least 4 times the operating weight of the unit
- it must allow level installation of the unit: although the unit is installed on a horizontal base, make slopes in the support surface to convey rain water or defrost water to drains, wells or in any case to places where it cannot generate an accident hazard due to ice formation. All heat pump version units are equipped with discharge manifolds for the condensed water; these can be manifolded to facilitate condensate discharge.

The units are designed and built to reduce to a minimum the level of vibration transmitted to the ground, but it is in any case advisable to use rubber or spring anti-vibration mounts, which are available as accessory and should be requested when ordering.

The anti-vibration mounts must be fixed on before positioning the unit on the ground.

In the event of installation on roofs or intermediate floors, the pipes must be isolated from the walls and ceilings.

It is advisable to avoid installation in cramped places, to prevent reverberations, reflections, resonances and acoustic interactions with elements outside the unit.

It is essential that any work done to soundproof the unit does not affect its correct installation or correct operation and, in particular, does not reduce the air flow rate to the source-side exchanger.

Installations that require the use of treated coils

If the unit has to be installed in an environment with a particularly aggressive atmosphere, coils with special treatments are available as options.

- coils with anti-corrosion treatment

A description of the individual accessories is available in the "Description of accessories" section.

The type of coil treatment should be chosen with regard to the environment in which the unit is to be installed, through observation of other structures and machinery with exposed metal surfaces present in the destination environment.

The cross observation criterion is the most valid method of selection currently available without having to carry out preliminary tests or measurements with instruments. The identified reference environments are:

- coastal/marine
- industrial
- urban with a high housing density
- rural

Please note that in cases where different conditions co-exist, even for short periods, the choice must be suitable for preserving the exchanger in the harsher environmental conditions and not in conditions between the worst and best situation.

Particular attention must be given in cases where an environment that is not particularly aggressive becomes aggressive as a consequence of a concomitant cause, for example, the presence of a flue outlet or an extraction fan.

We strongly suggest choosing one of the treatment options if at least one of the points listed below is verified:

- there are obvious signs of corrosion of the exposed metal surfaces in the installation area
- the prevailing winds come from the sea towards the unit
- the environment is industrial with a significant concentration of pollutants
- the environment is urban with a high population density
- the environment is rural with the presence of organic discharges and effluents

In particular, for installations near the coast, the following instructions apply:

- **For units to be installed between 1 and 20 km from the coast, the use of the option "Pre-painted aluminium coil" is strongly recommended.**
- **For units to be installed within one kilometre from the coast, the use of the option "Coil treated with anti-corrosion paints" is strongly recommended.**

To protect the exchangers from corrosion and ensure optimal operation of the unit, we advise following the recommendations given in the user, installation and maintenance manual for cleaning the coils.

Aeraulic head losses and options available for the ventilating section

With the exception of units for which oversize fans are required, as standard, the units are designed considering that, at the nominal air flow rate, the fans work with null available pressure.

If there are obstacles to free air flow, you should consider the additional aeraulic head losses that will cause a reduction of the air flow rate and a consequent deterioration of performance.

The following diagrams show the trend of cooling capacity (PC), EER, total absorbed power (Pabs) and reduction of the maximum external air temperature in chiller operating mode, depending on the aeraulic head losses that the fans will have to overcome.

AC fans (Ø 800)

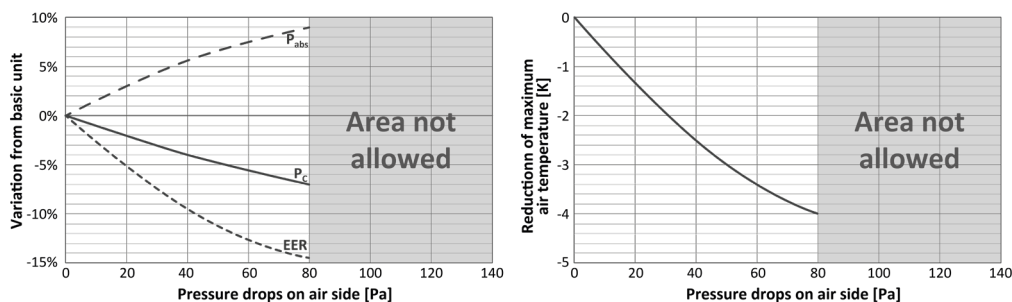

EC fans (Ø 800)

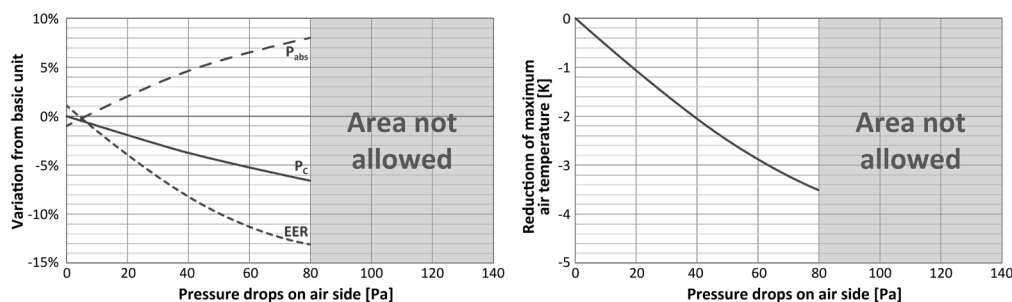

Oversize EC fans (Ø 800)

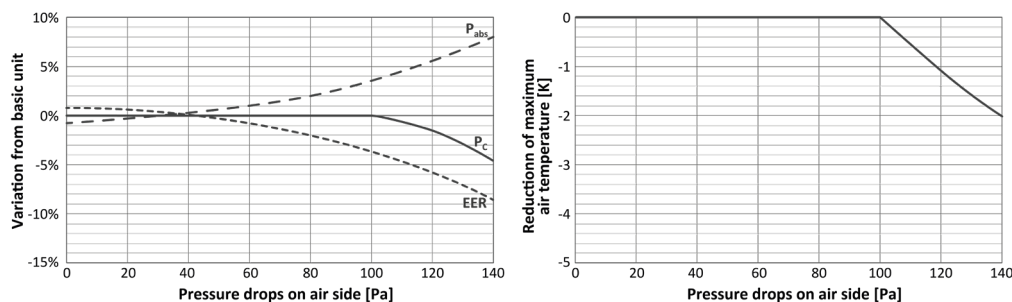

The indicated values are for the standard machine, without accessories, with AC fans and in any case in the absence of air recirculation.

Example: supposing you expect there to be obstacles that will generate an estimated aeraulic head loss of 60Pa. In this case, there are 3 possibilities:

- use the unit with standard AC fans: compared to ideal conditions, the output power will be reduced by about 5.5%, the total absorbed power will increase by about 7.5%, the EER will be reduced by about 12.5% and the maximum allowed external air temperature for operation at 100% will be reduced by about 3.4K compared to the nominal limit
- use the unit with EC fans: compared to the unit with AC fans working in ideal conditions, the output power will be reduced by about 5%, the total absorbed power will increase by about 6.5%, the EER will be reduced by about 11.5% and the maximum allowed external air temperature for operation at 100% will be reduced by about 2.8K compared to the nominal limit
- use the unit with oversize EC fans: compared to the unit with AC fans working in ideal conditions, the output power of the unit will be unchanged, the total absorbed power will increase by about 1%, the EER will be reduced by about 2% and the maximum external air temperature will remain the one shown in the diagram of the operating limits.

DIMENSIONAL DIAGRAMS

OMICRON REV S4 3.2- 4.2

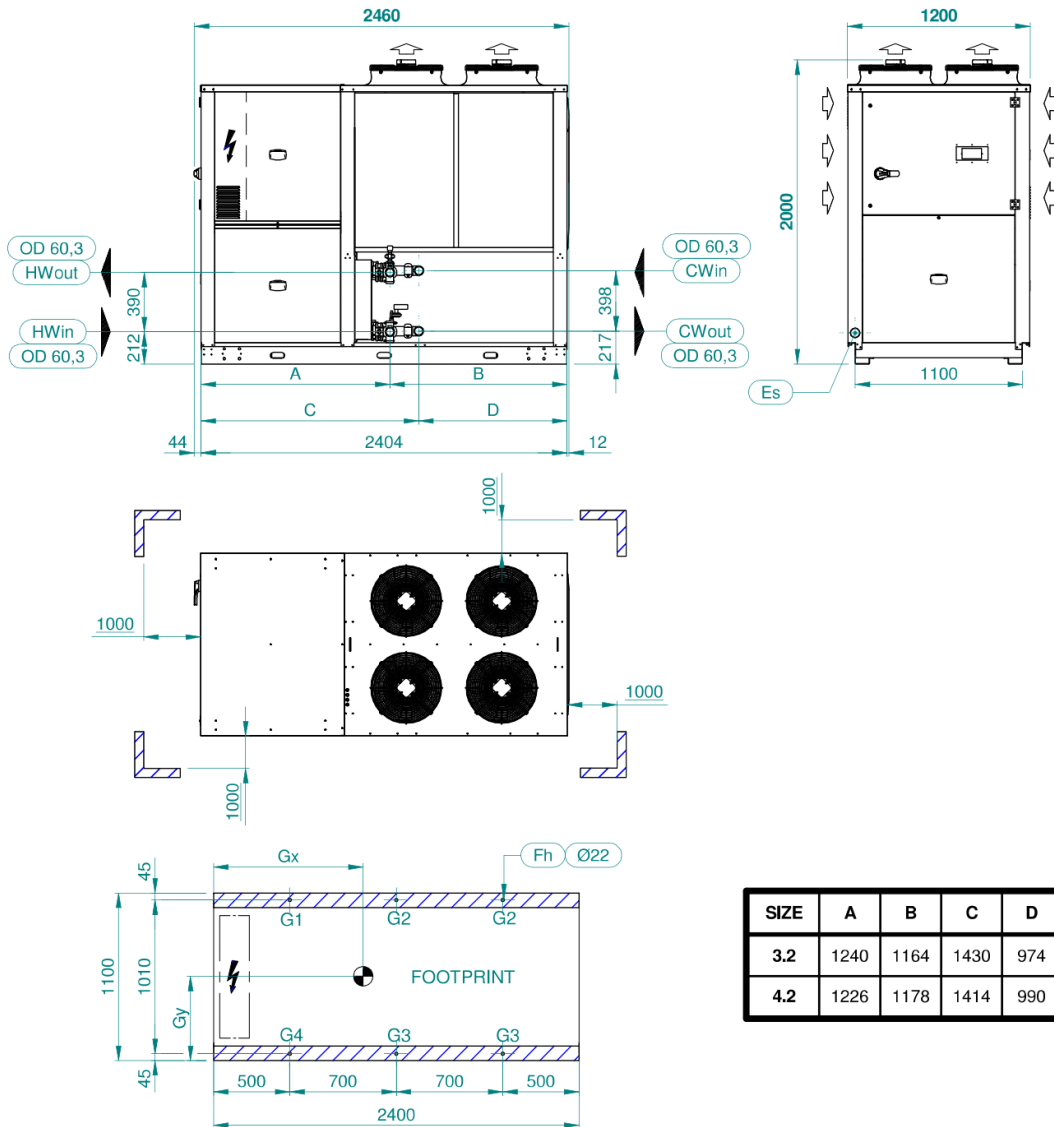

SIZE	A	B	C	D
3.2	1240	1164	1430	974
4.2	1226	1178	1414	990

MODEL	WEIGHT(kg)	OPERATING WEIGHT (kg)	G1 (kg)	G2 (kg)	G3 (kg)	G4 (kg)	Gx	Gy
HE S4 3.2	1050	1059	258	131	136	267	1029	542
HE S4 3.2 LN	1090	1099	278	131	136	287	1010	542
S4 SLN 3.2	1090	1099	278	131	136	287	1010	542
HE S4 4.2	1064	1075	267	131	135	276	1019	541
HE S4 4.2 LN	1104	1115	287	131	135	296	1000	542
S4 SLN 4.2	1104	1115	287	131	135	296	1000	542

Note: These drawings are not contractually binding. For the installation design, refer to the specific dimensional drawing available on request.

DIMENSIONAL DIAGRAMS

OMICRON REV S4 3.2- 4.2

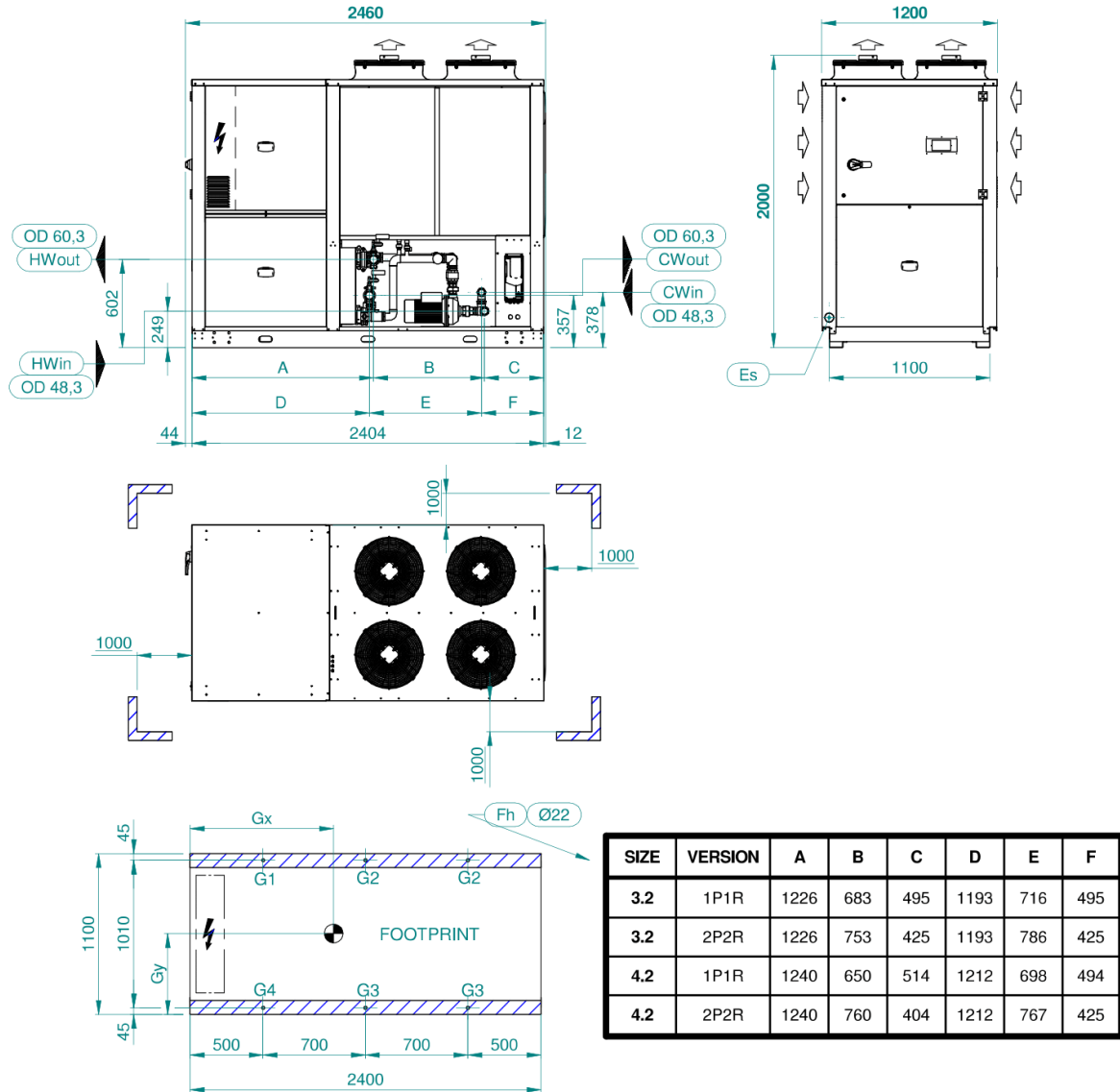

MODEL	WEIGHT (kg)	OPERATING WEIGHT (kg)	G1 (kg)	G2 (kg)	G3 (kg)	G4 (kg)	Gx	Gy
HE S4 3.2 1P1R/2P2R	1169	1193	256	166	171	263	1094	543
HE S4 3.2 LN 1P1R/2P2R	1211	1235	276	167	171	283	1074	543
S4 SLN 3.2 1P1R/2P2R	1211	1235	276	167	171	283	1074	543
HE S4 4.2 1P1R/2P2R	1184	1210	264	166	171	272	1084	542
HE S4 4.2 LN 1P1R/2P2R	1224	1250	284	166	171	292	1065	543
S4 SLN 4.2 1P1R/2P2R	1224	1250	284	166	171	292	1065	543

Note: These drawings are not contractually binding. For the installation design, refer to the specific dimensional drawing available on request.

DIMENSIONAL DIAGRAMS

OMICRON REV S4 5.2-7.2

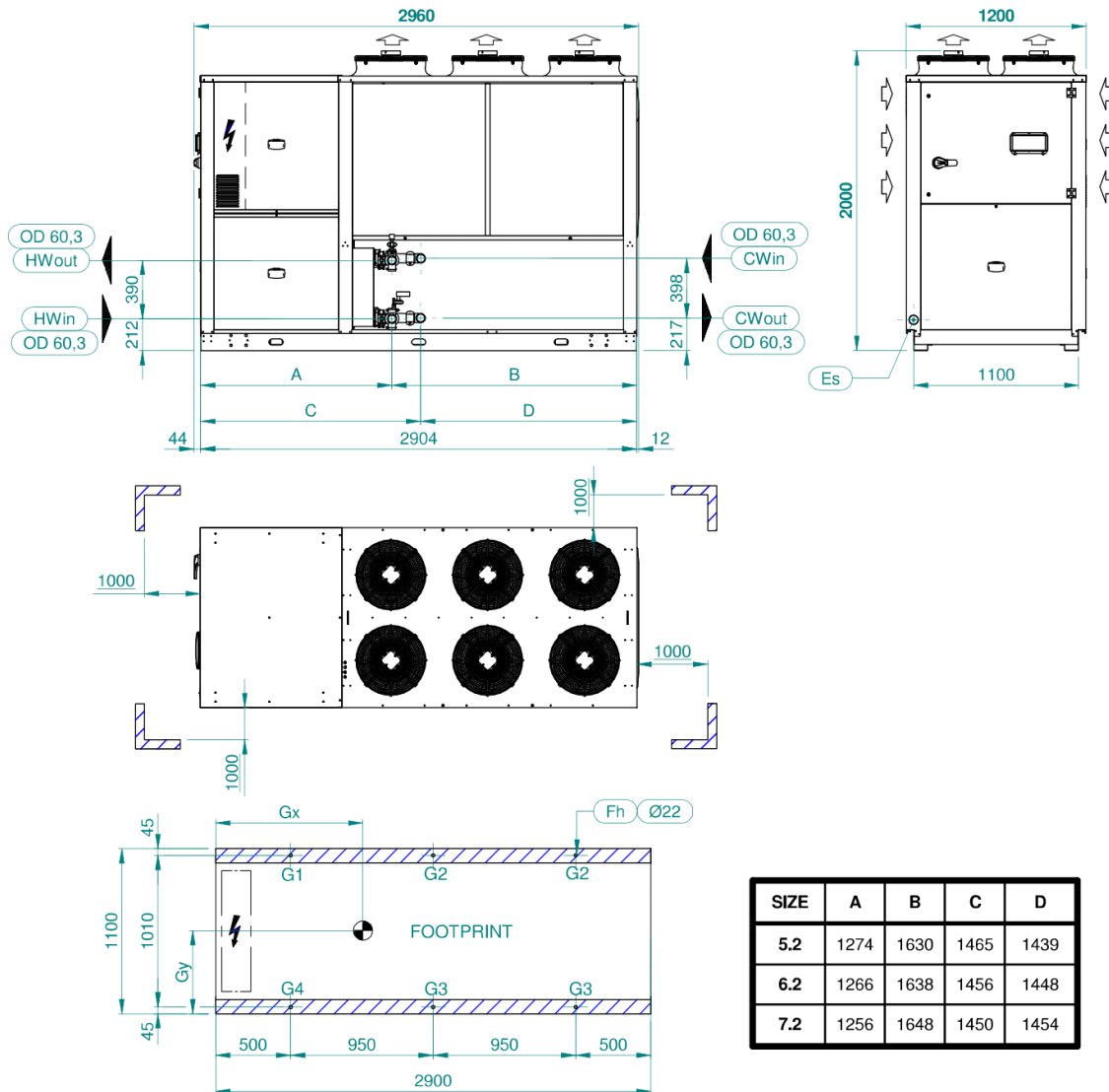

MODEL	WEIGHT (kg)	OPERATING WEIGHT (kg)	G1 (kg)	G2 (kg)	G3 (kg)	G4 (kg)	Gx	Gy
HE S4 5.2	1256	1269	307	159	164	316	1226	542
HE S4 5.2 LN	1294	1307	325	160	164	334	1206	543
S4 SLN 5.2	1294	1307	325	160	164	334	1206	543
HE S4 6.2	1256	1269	307	159	164	316	1226	542
HE S4 6.2 LN	1295	1308	326	159	164	336	1203	542
S4 SLN 6.2	1295	1308	326	159	164	336	1203	542
HE S4 7.2	1296	1311	327	159	164	338	1201	541
HE S4 7.2 LN	1337	1352	347	159	164	359	1181	541
S4 SLN 7.2	1337	1352	347	159	164	359	1181	541

Note: These drawings are not contractually binding. For the installation design, refer to the specific dimensional drawing available on request.

DIMENSIONAL DIAGRAMS

OMICRON REV S4 5.2-7.2

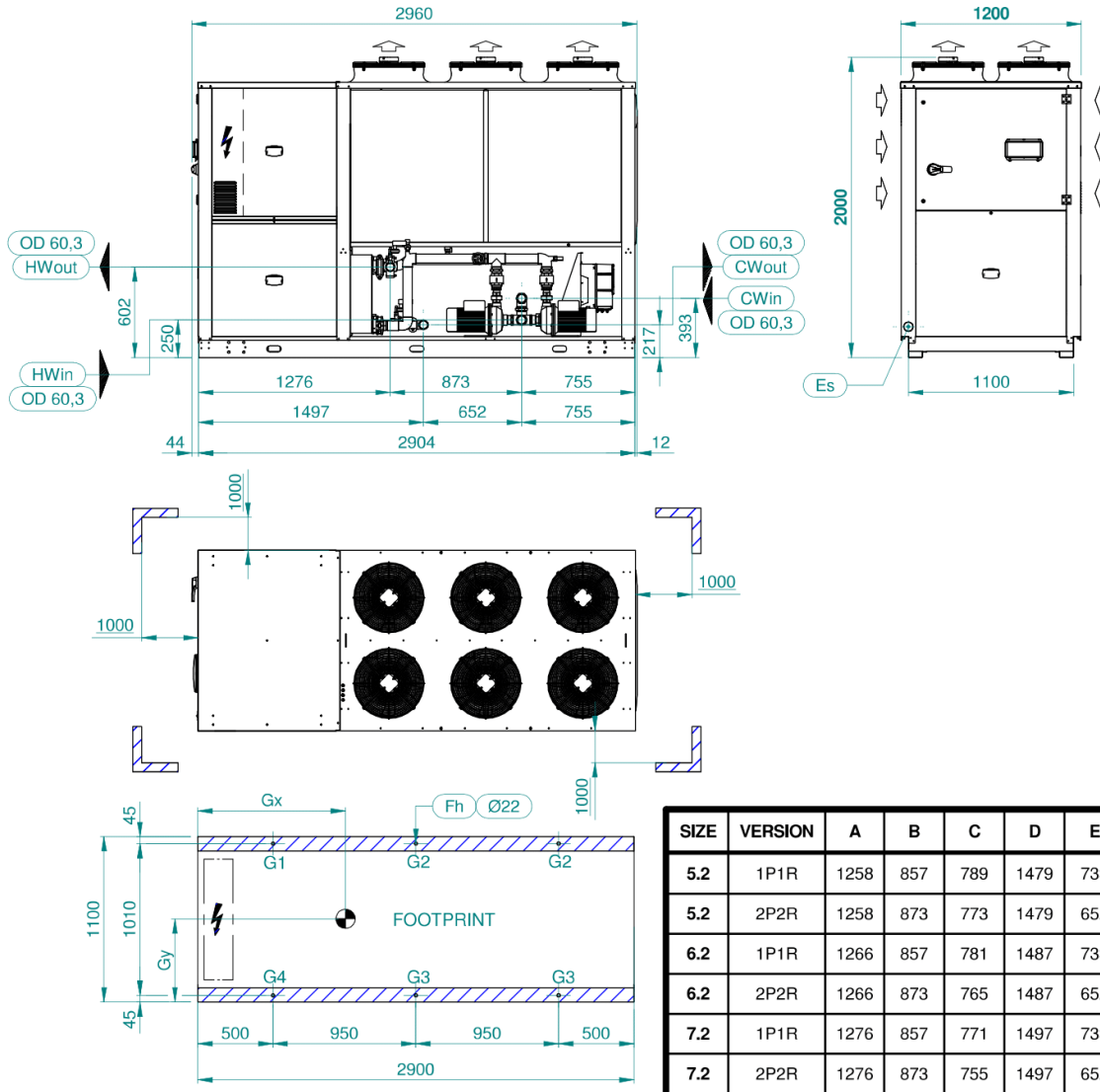

MODEL	WEIGHT(kg)	OPERATING WEIGHT (kg)	G1 (kg)	G2 (kg)	G3 (kg)	G4 (kg)	Gx	Gy
HE S4 5.2 1P1R/2P2R	1407	1442	297	207	213	305	1330	543
HE S4 5.2 LN 1P1R/2P2R	1443	1478	315	207	213	323	1310	543
S4 SLN 5.2 1P1R/2P2R	1443	1478	315	207	213	323	1310	543
HE S4 6.2 1P1R/2P2R	1412	1447	299	207	213	308	1327	543
HE S4 6.2 LN 1P1R/2P2R	1452	1487	319	207	213	328	1305	543
S4 SLN 6.2 1P1R/2P2R	1452	1487	319	207	213	328	1305	543
HE S4 7.2 1P1R/2P2R	1445	1482	317	206	213	327	1306	542
HE S4 7.2 LN 1P1R/2P2R	1487	1524	337	207	213	347	1285	542
S4 SLN 7.2 1P1R/2P2R	1487	1524	337	207	213	347	1285	542

Note: These drawings are not contractually binding. For the installation design, refer to the specific dimensional drawing available on request.

DIMENSIONAL DIAGRAMS

OMICRON REV S4 8.2-11.2

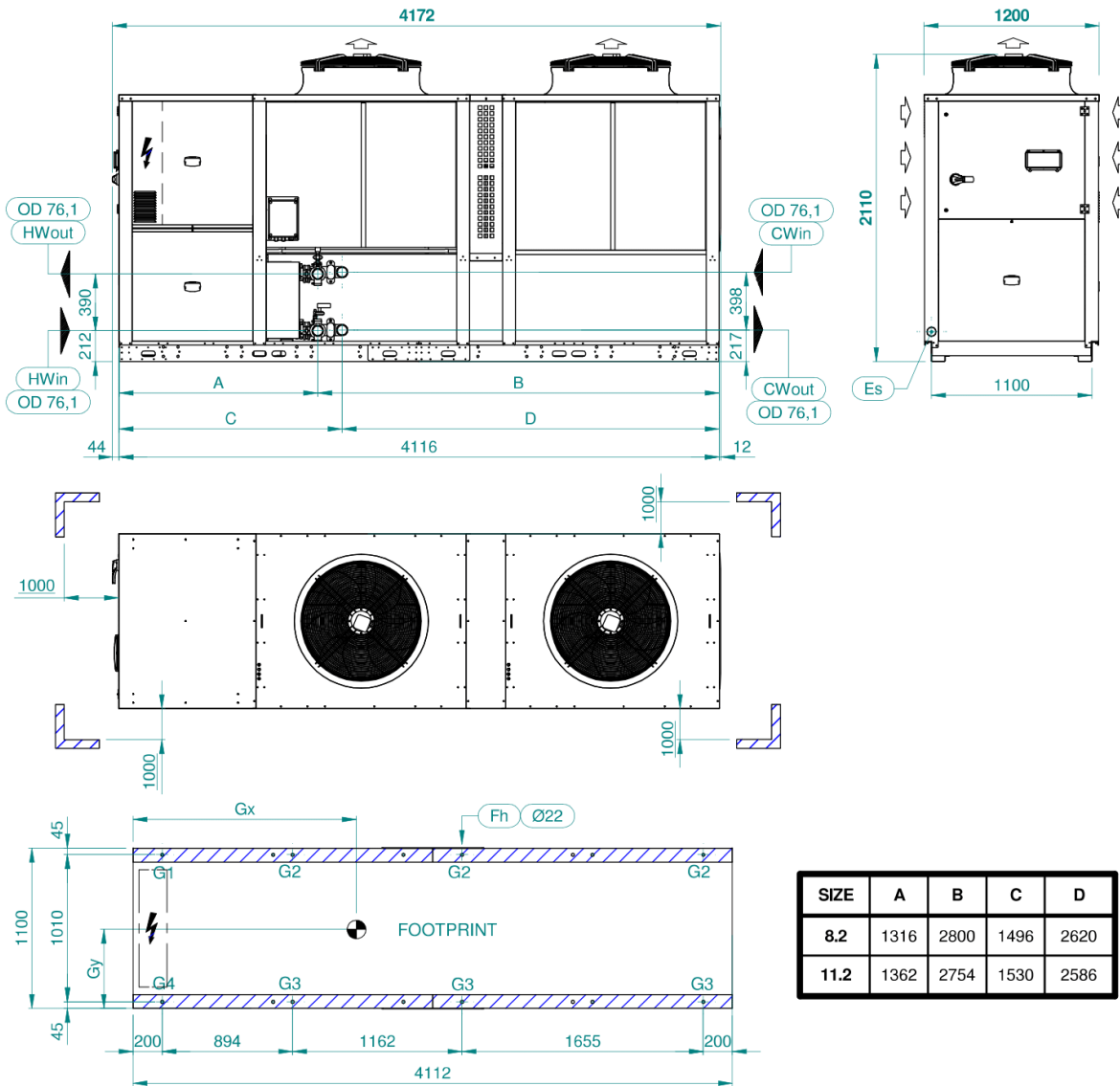

MODEL	WEIGHT (kg)	OPERATING WEIGHT (kg)	G1 (kg)	G2 (kg)	G3 (kg)	G4 (kg)	Gx	Gy
HE S4 8.2	1558	1576	226	162	167	233	1664	542
HE S4 8.2 LN	1596	1614	236	161	166	244	1635	542
S4 SLN 8.2	1596	1614	236	161	166	244	1635	542
HE S4 11.2	1618	1640	242	160	166	252	1617	541
HE S4 11.2 LN	1660	1682	253	160	166	262	1590	541
S4 SLN 11.2	1660	1682	253	160	166	262	1590	541

Note: These drawings are not contractually binding. For the installation design, refer to the specific dimensional drawing available on request.

DIMENSIONAL DIAGRAMS

OMICRON REV S4 8.2-11.2

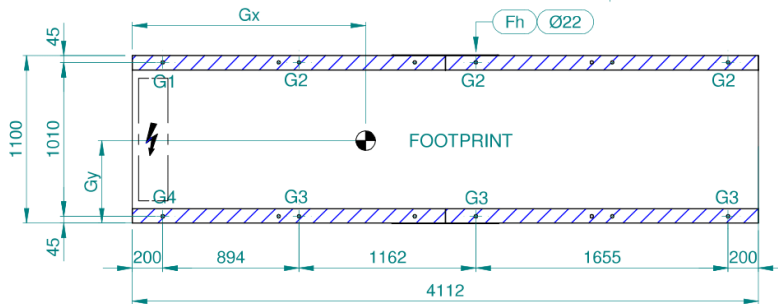
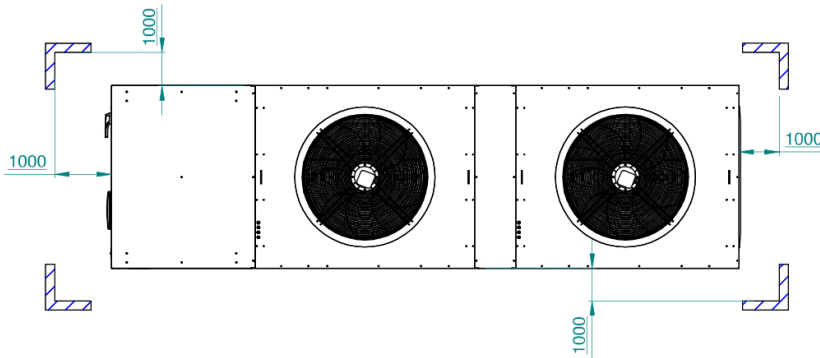
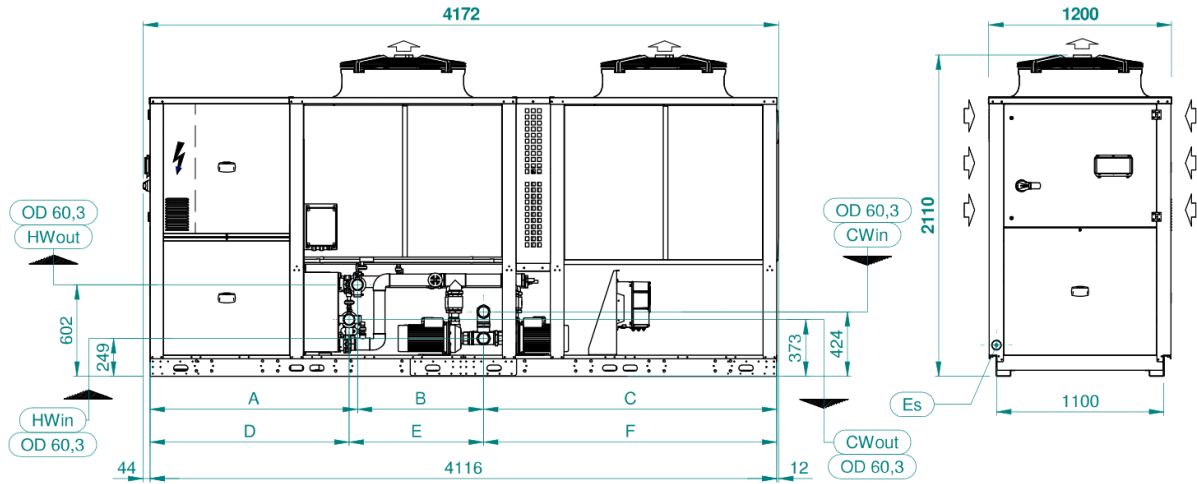

SIZE	VER.	A	B	C
8.2	1P1R	1362	828	1926
8.2	2P2R	1362	796	1958
11.2	1P1R	1316	874	1926
11.2	2P2R	1316	842	1958

SIZE	VER.	D	E	F
8.2	1P1R	1307	883	1926
8.2	2P2R	1307	856	1953
11.2	1P1R	1273	917	1926
11.2	2P2R	1273	890	1953

MODEL	WEIGHT (kg)	OPERATING WEIGHT (kg)	G1 (kg)	G2 (kg)	G3 (kg)	G4 (kg)	Gx	Gy
HE S4 8.2 1P1R/2P2R	1725	1778	245	193	199	252	1720	543
HE S4 8.2 LN 1P1R/2P2R	1767	1820	256	193	198	263	1693	543
S4 SLN 8.2 1P1R/2P2R	1767	1820	256	193	198	263	1693	543
HE S4 11.2 1P1R/2P2R	1789	1846	262	192	198	271	1676	542
HE S4 11.2 LN 1P1R/2P2R	1831	1888	273	191	198	282	1651	542
S4 SLN 11.2 1P1R/2P2R	1831	1888	273	191	198	282	1651	542

Note: These drawings are not contractually binding. For the installation design, refer to the specific dimensional drawing available on request.

DIMENSIONAL DIAGRAMS

OMICRON REV S4 14.2-16.2

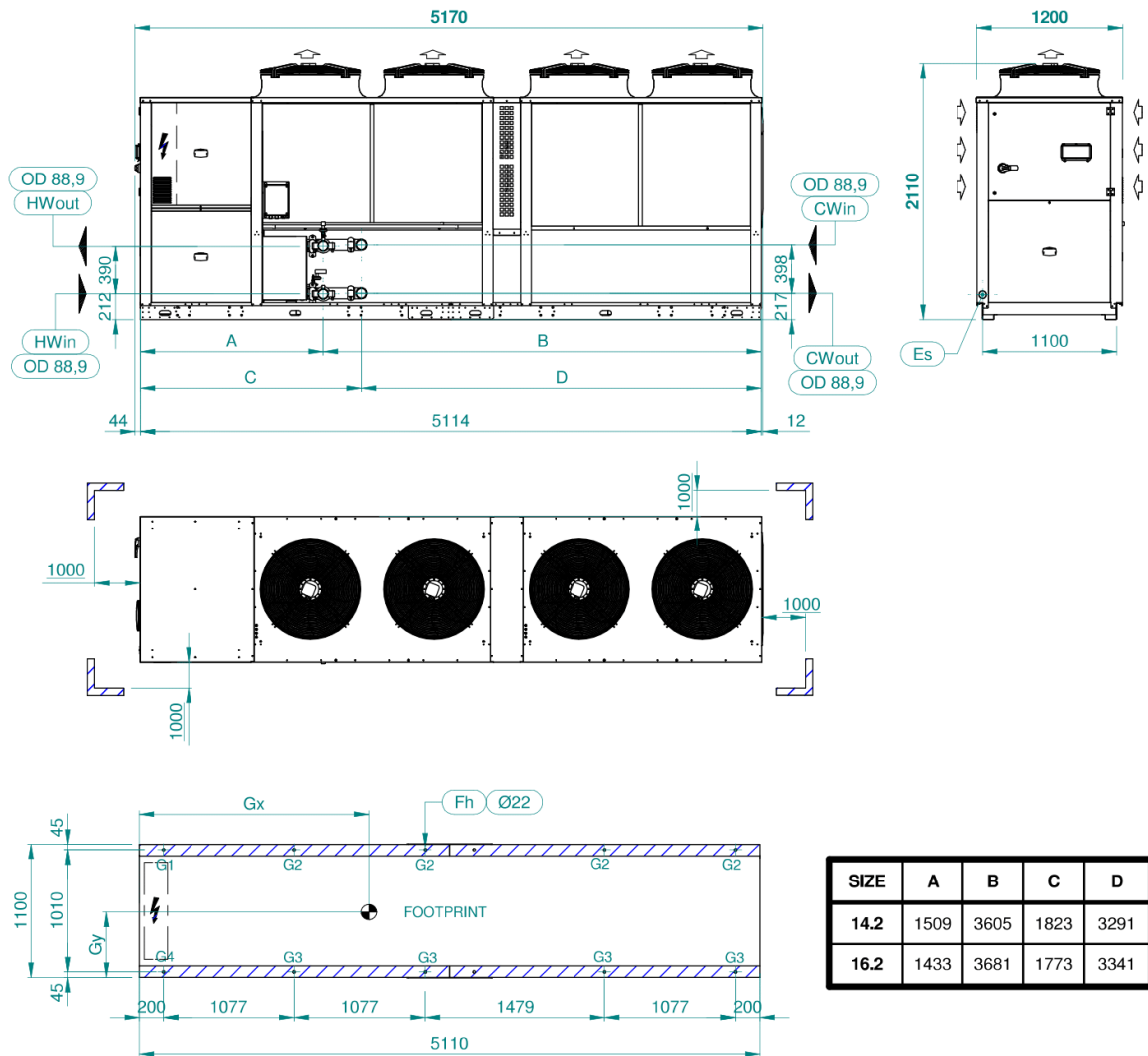

MODEL	WEIGHT(kg)	OPERATING WEIGHT (kg)	G1 (kg)	G2 (kg)	G3 (kg)	G4 (kg)	Gx	Gy
HE S4 14.2	1941	1969	271	142	147	280	2043	542
HE S4 14.2 LN	1985	2013	282	142	147	291	2012	542
S4 SLN 14.2	1985	2013	282	142	147	291	2012	542
HE S4 16.2	2128	2163	323	136	143	340	1883	537
HE S4 16.2 LN	2169	2204	334	136	142	351	1857	538
S4 SLN 16.2	2169	2204	334	136	142	351	1857	538

Note: These drawings are not contractually binding. For the installation design, refer to the specific dimensional drawing available on request.

DIMENSIONAL DIAGRAMS

OMICRON REV S4 14.2-16.2

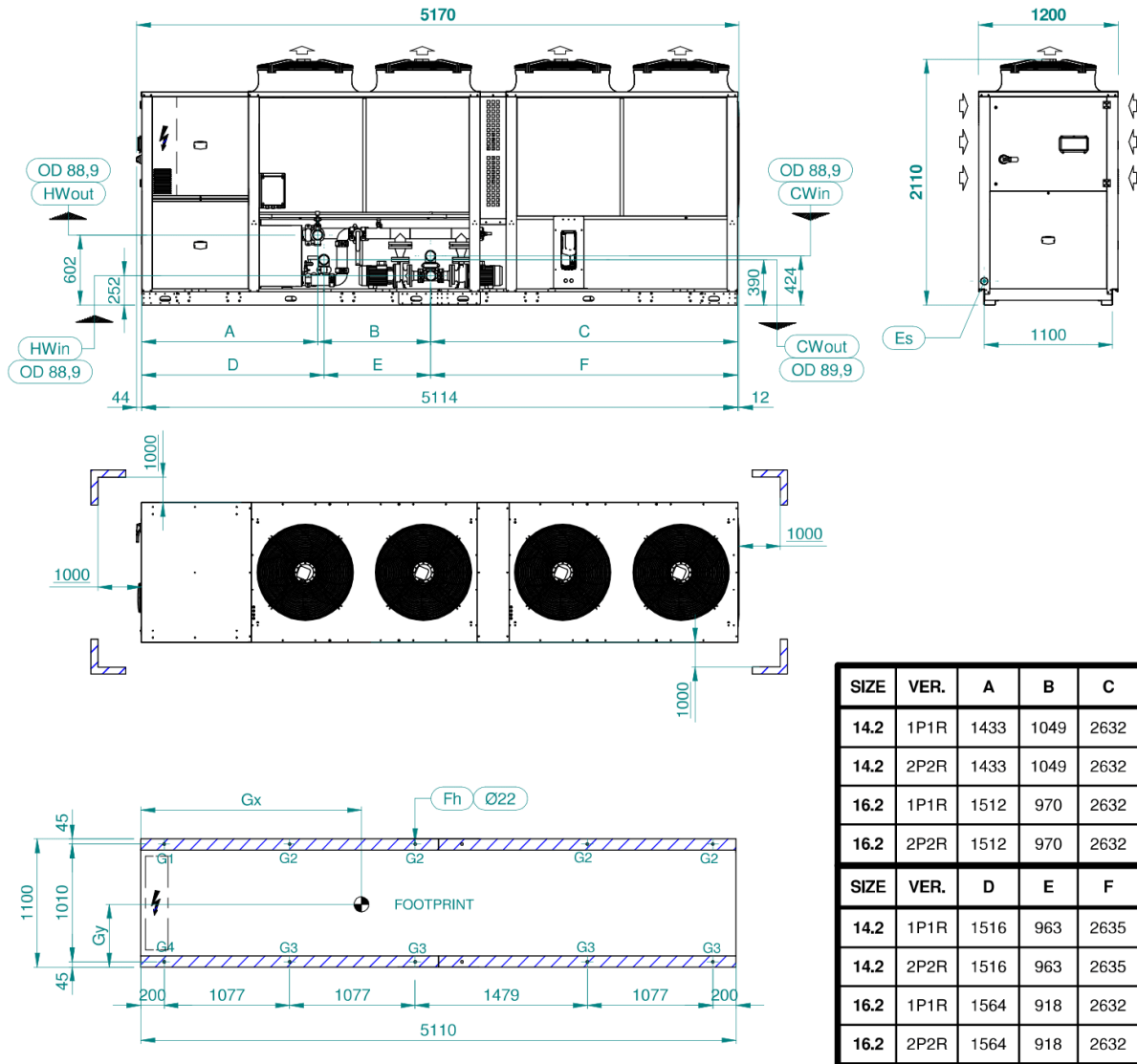

MODEL	WEIGHT(kg)	OPERATING WEIGHT (kg)	G1 (kg)	G2 (kg)	G3 (kg)	G4 (kg)	Gx	Gy
HE S4 14.2 1P1R/2P2R	2243	2321	317	170	175	326	2059	543
HE S4 14.2 LN 1P1R/2P2R	2282	2360	327	170	174	337	2033	543
S4 SLN 14.2 1P1R/2P2R	2282	2360	327	170	174	337	2033	543
HE S4 16.2 1P1R/2P2R	2430	2515	369	164	171	386	1920	539
HE S4 16.2 LN 1P1R/2P2R	2466	2551	380	163	170	396	1898	539
S4 SLN 16.2 1P1R/2P2R	2466	2551	380	163	170	396	1898	539

Note: These drawings are not contractually binding. For the installation design, refer to the specific dimensional drawing available on request.

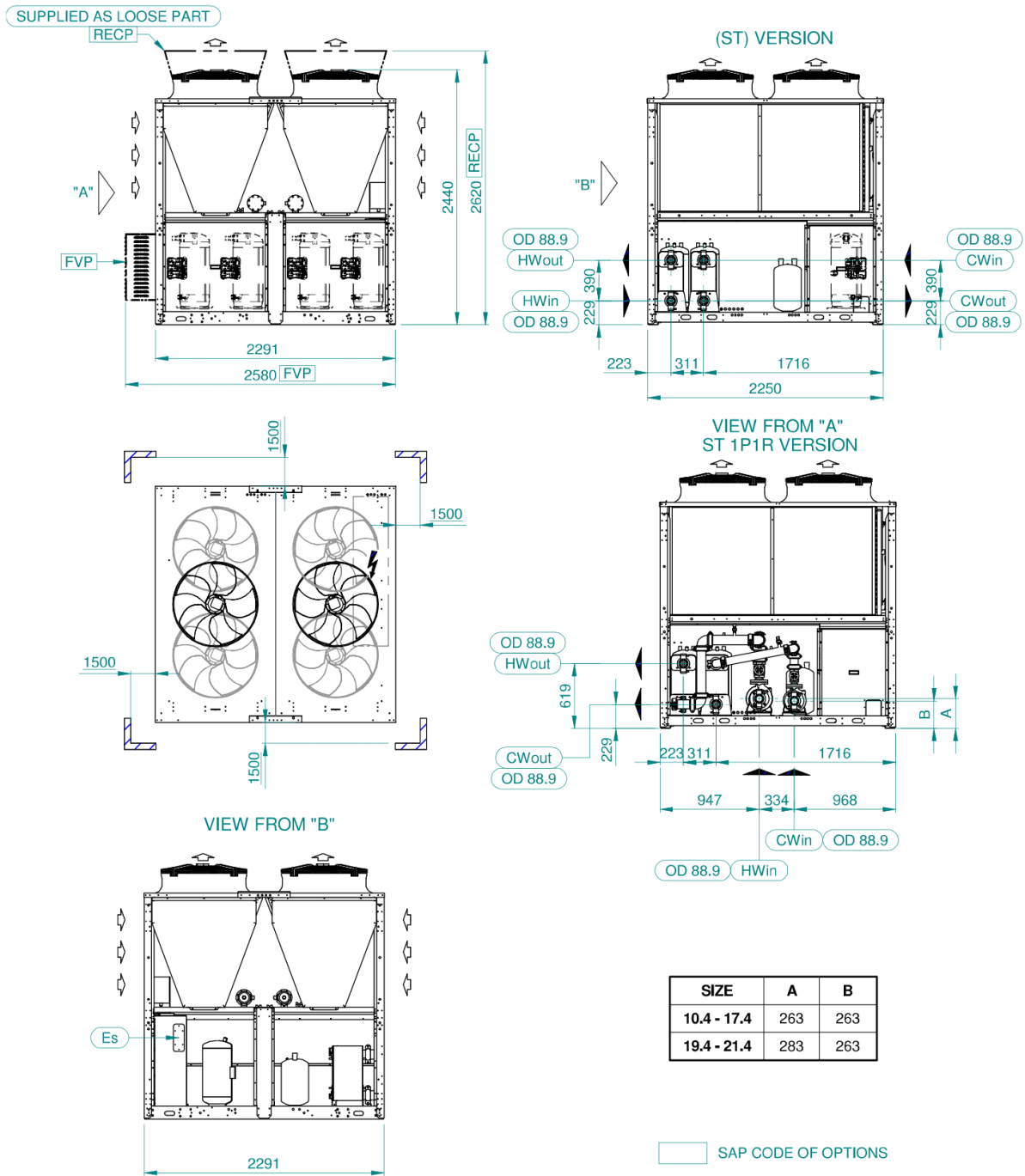

Note: These drawings are not contractually binding. For the installation design, refer to the specific dimensional drawing available on request.

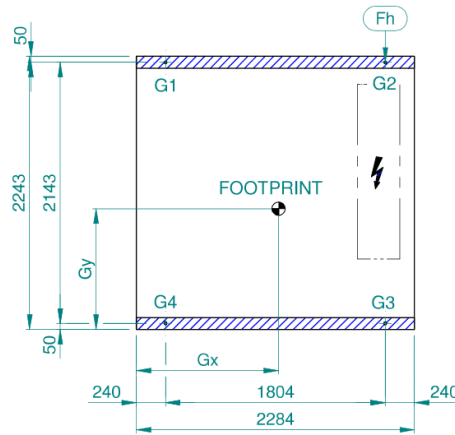

MODEL	WEIGHT(kg)	OPERATING WEIGHT (kg)	G1 (kg)	G2 (kg)	G3 (kg)	G4 (kg)	Gx	Gy
HE 10.4	1594	1606	362	412	443	389	1214	1077
HE 10.4 1P1R	1734	1806	454	423	448	481	1147	1082
HE 10.4 LN	1784	1796	377	423	527	469	1207	998
HE 10.4 1P1R_LN	1924	1996	465	437	530	564	1147	1008
SLN 10.4	1784	1796	377	423	527	469	1207	998
SLN 10.4 1P1R	1924	1996	465	437	530	564	1147	1008
HE 12.4	1610	1622	363	413	450	396	1213	1070
HE 12.4 1P1R	1750	1822	455	424	455	488	1147	1075
HE 12.4 LN	1800	1812	378	424	534	476	1206	992
HE 12.4 1P1R_LN	1939	2011	466	438	536	571	1147	1003
SLN 12.4	1800	1812	378	424	534	476	1206	992
SLN 12.4 1P1R	1939	2011	466	438	536	571	1147	1003
HE 17.4	1937	1958	464	498	516	480	1190	1095
HE 17.4 1P1R	2078	2159	557	508	522	572	1136	1097
HE 17.4 LN	2128	2149	478	510	599	562	1186	1027
HE 17.4 1P1R_LN	2268	2349	568	523	603	655	1137	1034
SLN 17.4	2128	2149	478	510	599	562	1186	1027
SLN 17.4 1P1R	2268	2349	568	523	603	655	1137	1034
HE 19.4	1964	1985	470	501	523	491	1186	1090
HE 19.4 1P1R	2105	2186	563	511	529	583	1133	1093
HE 19.4 LN	2154	2175	484	513	606	572	1183	1024
HE 19.4 1P1R_LN	2294	2375	574	525	610	666	1135	1030
SLN 19.4	2154	2175	484	513	606	572	1183	1024
SLN 19.4 1P1R	2294	2375	574	525	610	666	1135	1030
HE 21.4	1981	2002	472	502	530	498	1186	1084
HE 21.4 1P1R	2131	2212	569	513	536	594	1130	1088
HE 21.4 LN	2170	2191	485	514	613	579	1182	1019
HE 21.4 1P1R_LN	2320	2401	580	527	616	678	1131	1027
SLN 21.4	2170	2191	485	514	613	579	1182	1019
SLN 21.4 1P1R	2320	2401	580	527	616	678	1131	1027

Note: These drawings are not contractually binding. For the installation design, refer to the specific dimensional drawing available on request.

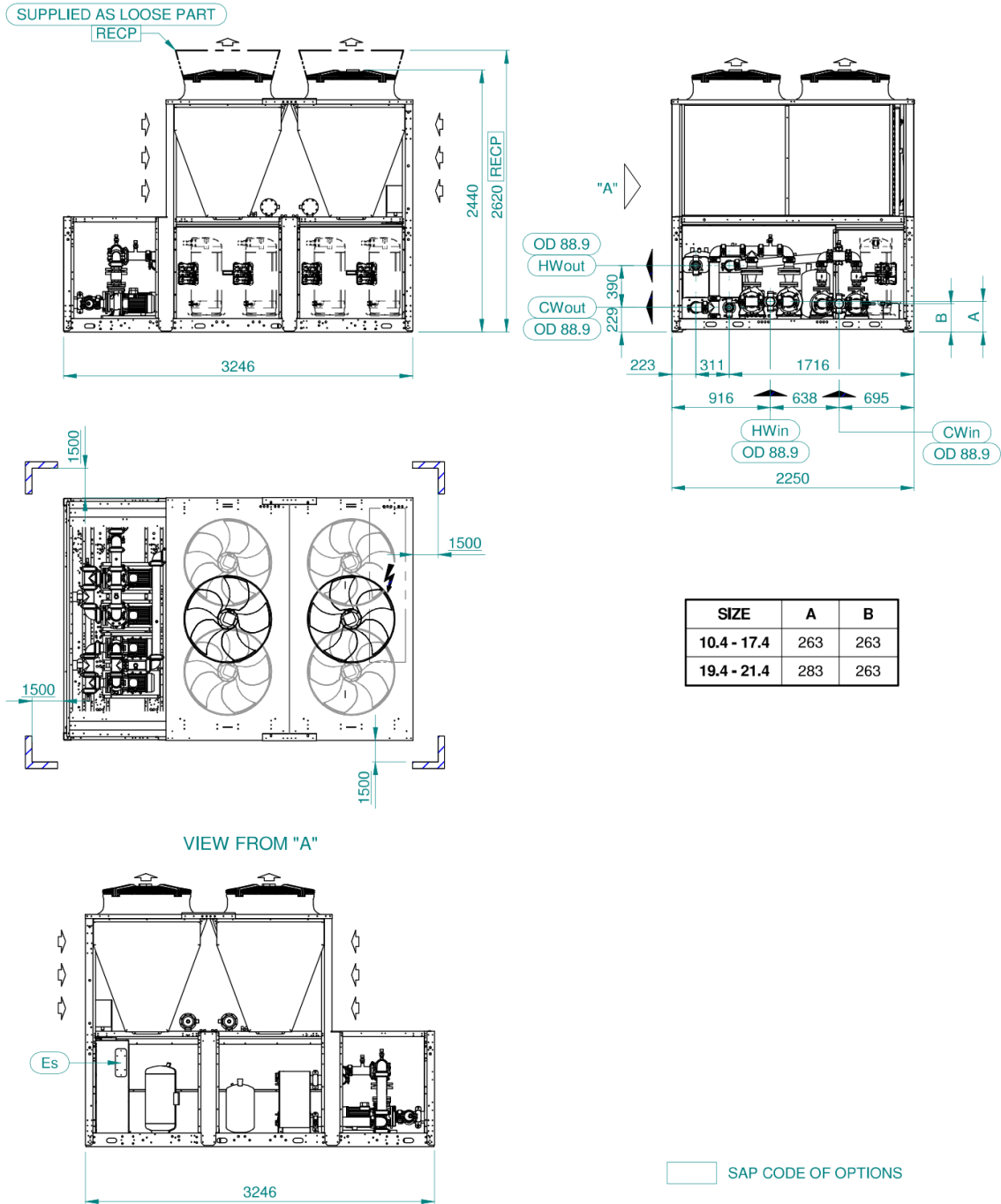

Note: These drawings are not contractually binding. For the installation design, refer to the specific dimensional drawing available on request.

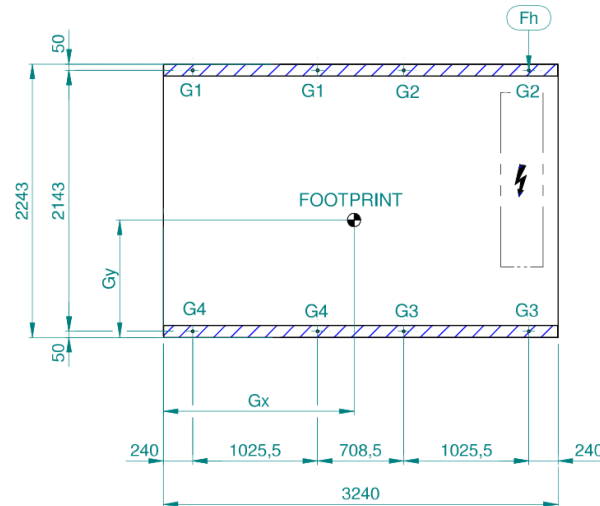

MODEL	WEIGHT (kg)	OPERATING WEIGHT (kg)	G1 (kg)	G2 (kg)	G3 (kg)	G4 (kg)	Gx	Gy
HE 10.4 2P2R	1916	2008	204	274	302	224	1800	1068
HE 10.4 2P2R_LN	2106	2198	201	290	360	248	1827	1002
SLN 10.4 2P2R	2106	2198	201	290	360	248	1827	1002
HE 12.4 2P2R	1932	2024	203	276	307	226	1802	1062
HE 12.4 2P2R_LN	2122	2214	200	292	364	251	1828	997
SLN 12.4 2P2R	2122	2214	200	292	364	251	1828	997
HE 17.4 2P2R	2261	2362	231	341	363	246	1835	1084
HE 17.4 2P2R_LN	2449	2550	228	357	421	269	1855	1026
SLN 17.4 2P2R	2449	2550	228	357	421	269	1855	1026
HE 19.4 2P2R	2287	2388	232	344	369	249	1835	1079
HE 19.4 2P2R_LN	2477	2578	230	359	427	273	1855	1022
SLN 19.4 2P2R	2477	2578	230	359	427	273	1855	1022
HE 21.4 2P2R	2303	2404	236	341	369	256	1823	1074
HE 21.4 2P2R_LN	2495	2596	230	361	432	275	1857	1018
SLN 21.4 2P2R	2495	2596	230	361	432	275	1857	1018

Note: These drawings are not contractually binding. For the installation design, refer to the specific dimensional drawing available on request.

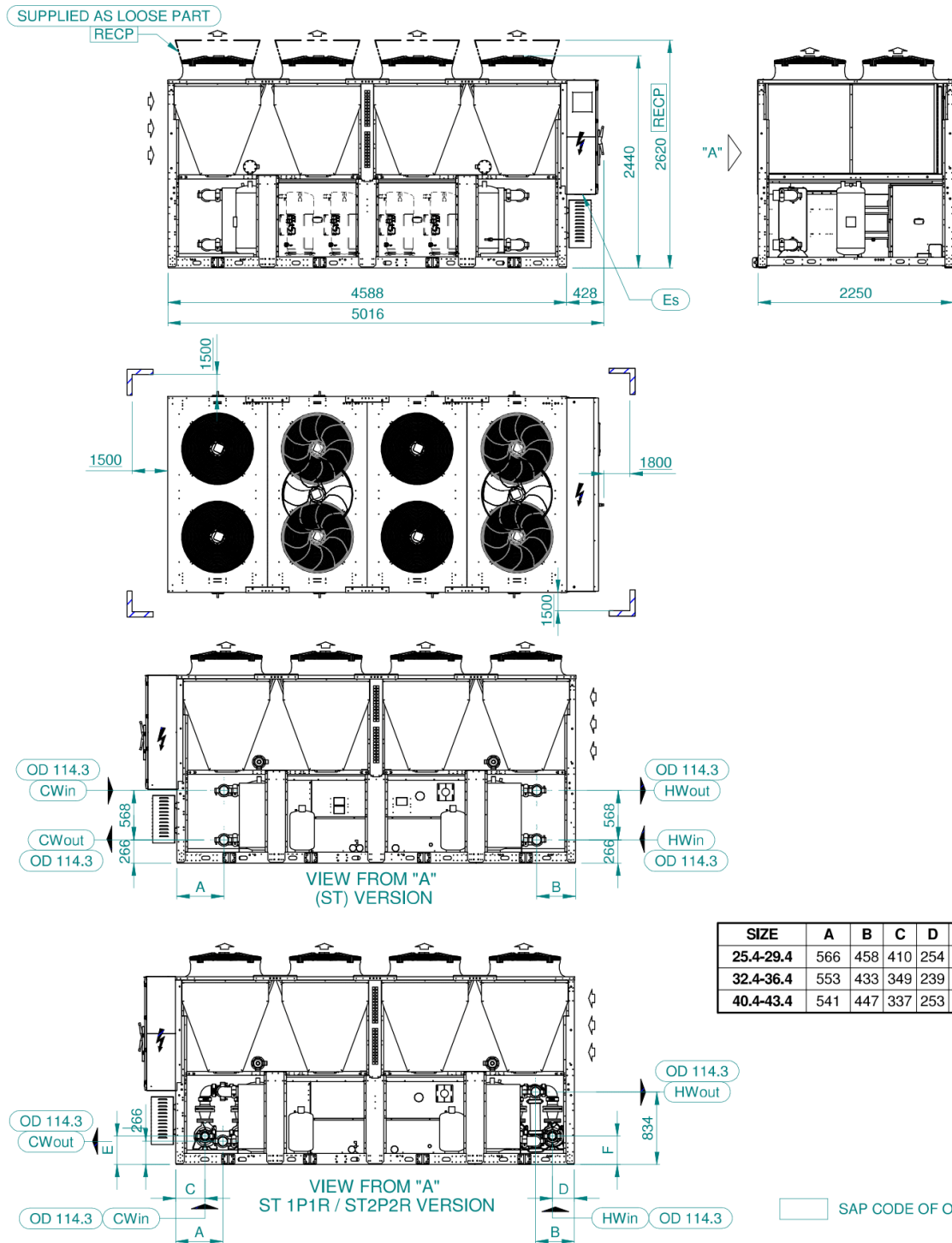

Note: These drawings are not contractually binding. For the installation design, refer to the specific dimensional drawing available on request.

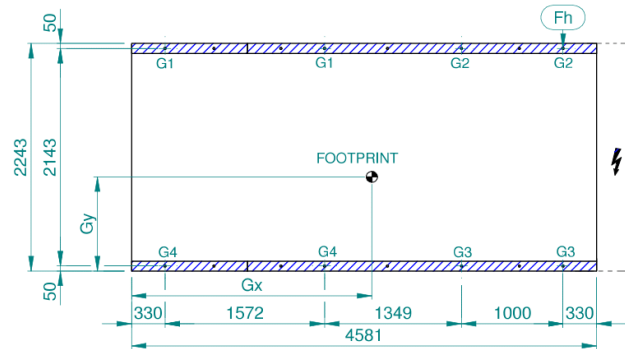

MODEL	WEIGHT (kg)	OPERATING WEIGHT (kg)	G1 (kg)	G2 (kg)	G3 (kg)	G4 (kg)	Gx	Gy
HE 25.4	3440	3496	376	422	502	448	2511	1015
HE 25.4 1P1R	3670	3766	379	493	572	439	2596	1026
HE 25.4 2P2R	3992	3978	418	443	580	548	2474	968
HE 25.4 LN	3614	3670	385	425	538	487	2500	983
HE 25.4 1P1R_LN	3864	3950	410	437	582	546	2478	959
HE 25.4 2P2R_LN	4068	4154	427	447	615	588	2466	942
SLN 25.4	3614	3670	385	425	538	487	2500	983
SLN 25.4 1P1R	3864	3950	410	437	582	546	2478	959
SLN 25.4 2P2R	4068	4154	427	447	615	588	2466	942
HE 29.4	3465	3524	378	428	508	448	2516	1016
HE 29.4 1P1R	3713	3802	403	439	552	507	2492	989
HE 29.4 2P2R	3915	4004	420	449	585	548	2478	969
HE 29.4 LN	3639	3698	387	431	543	488	2505	985
HE 29.4 1P1R_LN	3891	3980	412	443	588	547	2483	961
HE 29.4 2P2R_LN	4091	4180	429	453	620	588	2471	943
SLN 29.4	3639	3698	387	431	543	488	2505	985
SLN 29.4 1P1R	3891	3980	412	443	588	547	2483	961
SLN 29.4 2P2R	4091	4180	429	453	620	588	2471	943
HE 32.4	3792	3866	412	482	560	479	2538	1026
HE 32.4 1P1R	4042	4146	438	493	605	537	2514	1000
HE 32.4 2P2R	4246	4350	455	503	639	578	2501	982
HE 32.4 LN	3970	4044	422	486	596	518	2527	996
HE 32.4 1P1R_LN	4220	4324	447	497	641	577	2505	973
HE 32.4 2P2R_LN	4420	4524	464	506	674	618	2493	957
SLN 32.4	3970	4044	422	486	596	518	2527	996
SLN 32.4 1P1R	4220	4324	447	497	641	577	2505	973
SLN 32.4 2P2R	4420	4524	464	506	674	618	2493	957
HE 36.4	3839	3912	416	485	568	487	2535	1022
HE 36.4 1P1R	4110	4214	444	497	616	550	2511	995
HE 36.4 2P2R	4310	4414	461	506	649	591	2498	977
HE 36.4 LN	4016	4090	426	489	604	526	2525	993
HE 36.4 1P1R_LN	4286	4390	453	501	652	589	2502	969
HE 36.4 2P2R_LN	4486	4590	470	510	685	630	2490	953
SLN 36.4	4016	4090	426	489	604	526	2525	993
SLN 36.4 1P1R	4286	4390	453	501	652	589	2502	969
SLN 36.4 2P2R	4486	4590	470	510	685	630	2490	953
HE 40.4	3910	3996	429	504	575	490	2538	1033
HE 40.4 1P1R	4184	4300	457	516	624	553	2514	1006
HE 40.4 2P2R	4382	4498	474	525	657	593	2501	988
HE 40.4 LN	4086	4172	439	507	611	529	2528	1004
HE 40.4 1P1R_LN	4356	4472	466	519	659	592	2505	980
HE 40.4 2P2R_LN	4556	4672	483	528	692	633	2493	963
SLN 40.4	4086	4172	439	507	611	529	2528	1004
SLN 40.4 1P1R	4356	4472	466	519	659	592	2505	980
SLN 40.4 2P2R	4556	4672	483	528	692	633	2493	963
HE 43.4	3970	4056	432	505	588	503	2535	1023
HE 43.4 1P1R	4247	4370	456	517	644	568	2517	991
HE 43.4 2P2R	4447	4570	473	526	677	609	2504	974
HE 43.4 LN	4133	4216	436	507	627	538	2531	992
HE 43.4 1P1R_LN	4423	4546	465	521	680	607	2508	966
HE 43.4 2P2R_LN	4623	4746	482	530	713	648	2496	951
SLN 43.4	4133	4216	436	507	627	538	2531	992
SLN 43.4 1P1R	4423	4546	465	521	680	607	2508	966
SLN 43.4 2P2R	4623	4746	482	530	713	648	2496	951

Note: These drawings are not contractually binding. For the installation design, refer to the specific dimensional drawing available on request.

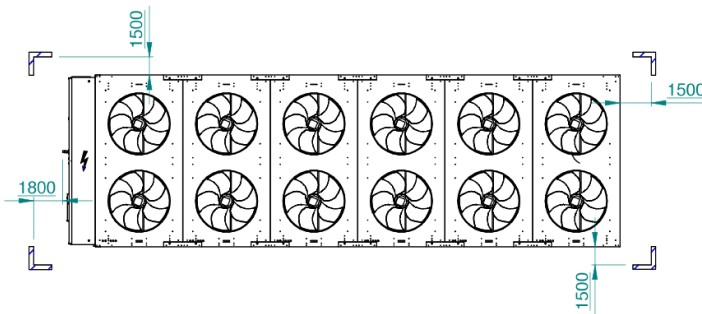
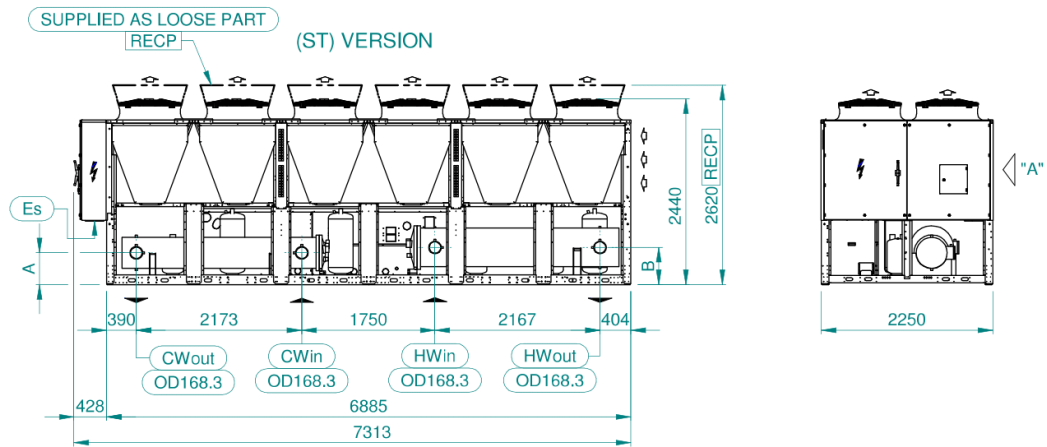

VIEW FROM "A"
ST 1P1R / 2P2R VERSION

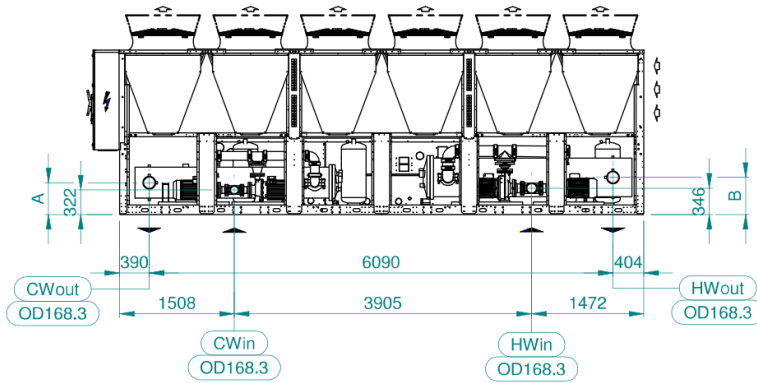

SIZE	A	B
51.6 - 52.6	391	418
60.6 - 61.6	418	488

□ SAP CODE OF OPTIONS

Note: These drawings are not contractually binding. For the installation design, refer to the specific dimensional drawing available on request.

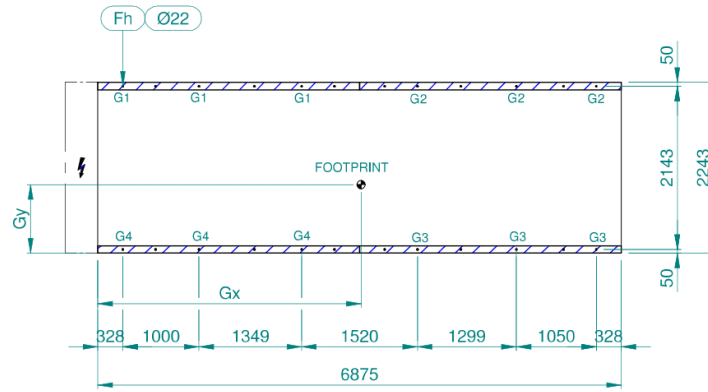

MODEL	WEIGHT(kg)	OPERATING WEIGHT (kg)	G1 (kg)	G2 (kg)	G3 (kg)	G4 (kg)	Gx	Gy
HE 51.6 - 52.6	6399	6849	662	545	486	590	3205	1219
HE 51.6 - 52.6 1P1R	6740	7230	666	560	541	643	3229	1177
HE 51.6 - 52.6 2P2R	7079	7569	670	574	590	689	3250	1139
HE 51.6 - 52.6 LN	6642	7092	704	572	488	600	3193	1243
HE 51.6 - 52.6 1P1R_LN	6977	7467	707	587	542	653	3216	1202
HE 51.6 - 52.6 2P2R_LN	7322	7812	711	602	592	699	3238	1164
SLN 51.6 - 52.6	6642	7092	704	572	488	600	3193	1243
SLN 51.6 - 52.6 1P1R	6977	7467	707	587	542	653	3216	1202
SLN 51.6 - 52.6 2P2R	7322	7812	711	602	592	699	3238	1164
HE 60.6 - 61.6	6658	7443	710	571	535	665	3197	1208
HE 60.6 - 61.6 1P1R	6999	7824	714	587	590	717	3220	1169
HE 60.6 - 61.6 2P2R	7338	8163	717	601	640	763	3241	1132
HE 60.6 - 61.6 LN	6901	7686	752	598	537	675	3185	1232
HE 60.6 - 61.6 1P1R_LN	7236	8061	755	614	591	727	3208	1193
HE 60.6 - 61.6 2P2R_LN	7581	8406	759	628	641	774	3229	1157
SLN 60.6 - 61.6	6901	7686	752	598	537	675	3185	1232
SLN 60.6 - 61.6 1P1R	7236	8061	755	614	591	727	3208	1193
SLN 60.6 - 61.6 2P2R	7581	8406	759	628	641	774	3229	1157

Note: These drawings are not contractually binding. For the installation design, refer to the specific dimensional drawing available on request.

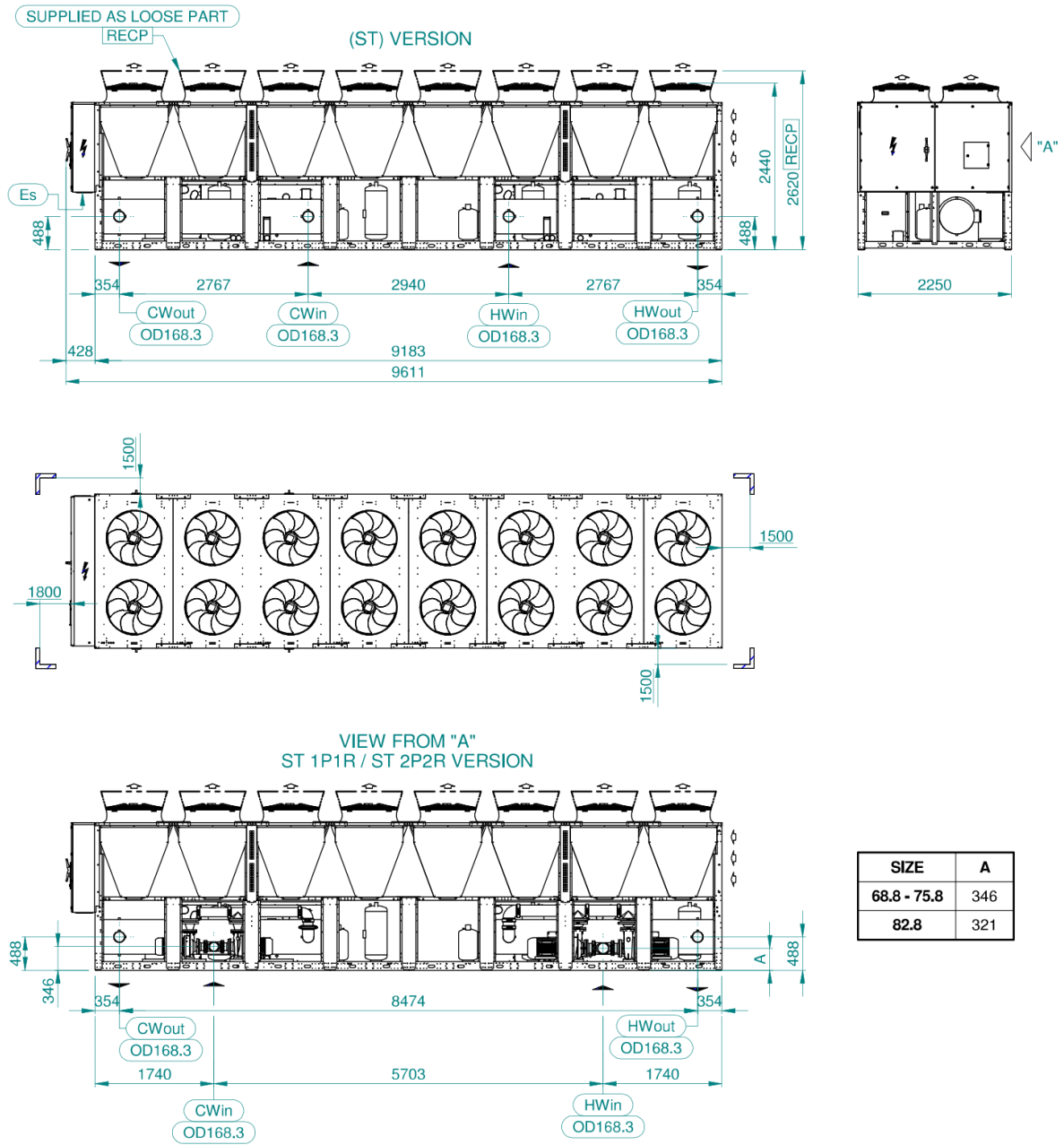

□ SAP CODE OF OPTIONS

Note: These drawings are not contractually binding. For the installation design, refer to the specific dimensional drawing available on request.

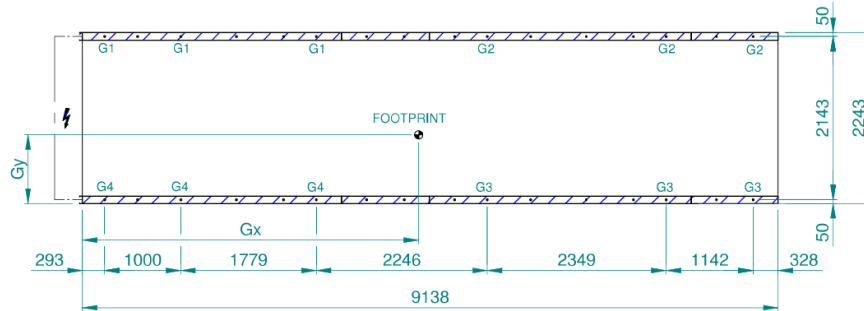

MODEL	WEIGHT(kg)	OPERATING WEIGHT (kg)	G1 (kg)	G2 (kg)	G3 (kg)	G4 (kg)	Gx	Gy
HE 68.8	8127	9177	801	783	729	746	4417	1168
HE 68.8 1P1R	8580	9690	809	795	806	820	4425	1125
HE 68.8 2P2R	9030	10140	815	806	874	885	4414	1240
HE 68.8 LN	8451	9501	845	829	740	753	4423	1193
HE 68.8 1P1R_LN	8898	10008	852	841	816	827	4431	1150
HE 68.8 2P2R_LN	9354	10464	859	852	885	892	4414	1240
SLN 68.8 SLN	8451	9501	845	829	740	753	4423	1193
SLN 68.8 1P1R	8898	10008	852	841	816	827	4431	1150
SLN 68.8 2P2R	9354	10464	859	852	885	892	4451	1210
HE 75.8	8250	9300	797	801	753	749	4459	1163
HE 75.8 1P1R	8700	9810	805	813	830	822	4465	1121
HE 75.8 2P2R	9153	10263	812	823	899	887	4456	1234
HE 75.8 LN	8568	9618	840	847	763	756	4463	1187
HE 75.8 1P1R_LN	9021	10131	848	859	840	830	4469	1145
HE 75.8 2P2R_LN	9468	10578	855	869	908	894	4456	1234
SLN 75.8 SLN	8568	9618	840	847	763	756	4463	1187
SLN 75.8 1P1R	9021	10131	848	859	840	830	4469	1145
SLN 75.8 2P2R	9468	10578	855	869	908	894	4495	1204
HE 82.8	8370	9420	793	819	776	752	4500	1158
HE 82.8 1P1R	8823	9933	802	830	854	825	4504	1116
HE 82.8 2P2R	9273	10383	809	840	923	889	4498	1228
HE 82.8 LN	8688	9738	836	865	786	759	4503	1182
HE 82.8 1P1R_LN	9138	10248	845	876	863	832	4507	1141
HE 82.8 2P2R_LN	9588	10698	852	886	932	896	4498	1228
SLN 82.8 SLN	8688	9738	836	865	786	759	4503	1182
SLN 82.8 1P1R	9138	10248	845	876	863	832	4507	1141
SLN 82.8 2P2R	9588	10698	852	886	932	896	2496	951

Note: These drawings are not contractually binding. For the installation design, refer to the specific dimensional drawing available on request.





WESTERNTM
AIRCONDITIONING
WARMTEPOMPEN

BlueBox 
by Swegon